

Fuse Box

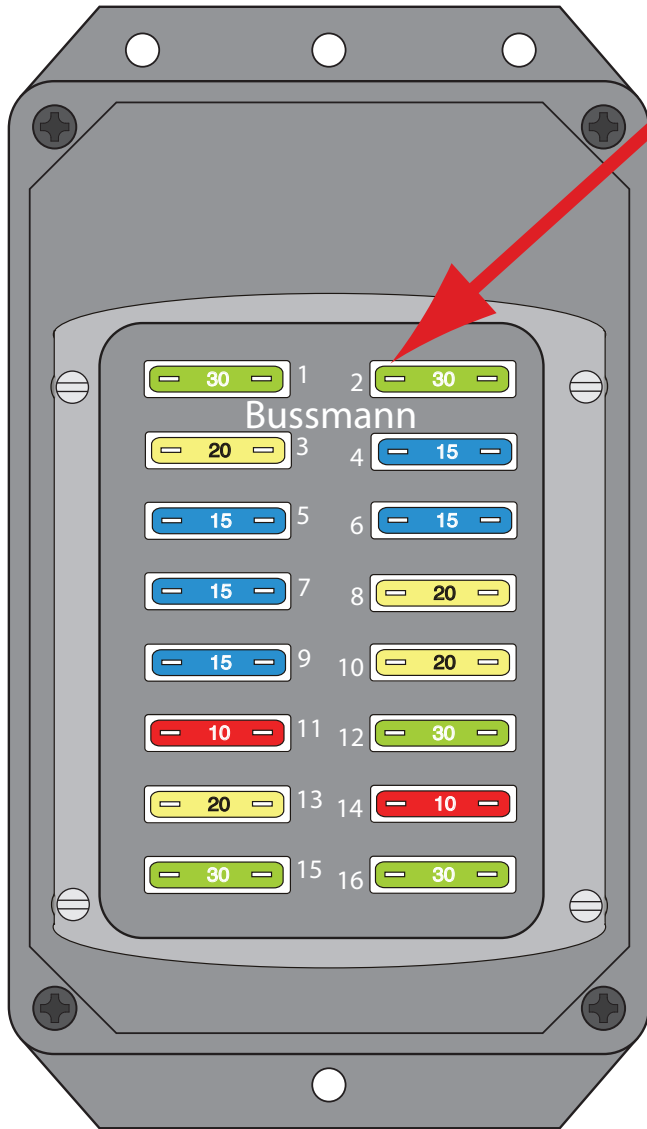

**NOTE:**

If your fuse box looks like this, these **ARE** the correct instructions for your application. If the word “Busmann” does not appear on the fuse box, you have a different version of this kit and these **ARE NOT** the correct instructions.

**KIT BOX CONTENTS**

Bag	Number	Description	Quantity
	500042	Floor Dimmer Switch	1
	500919	Practice Terminal Crimping Set	1
	510128	Ignition Switch	1
	510145	Fuse, Relay, and Flasher Kit	1
G	510318	Dash and Main Harness Kit	1
H	510319	Dash Cluster Kit	1
M	510320	Rear Body Kit	1
	510321	Headlight Switch	1
	510322	Wiper Switch	1
	510323	Grommet and Parts Kit	1
Z	510476	Alternator and Main Connection kit	1
	92970069	Instruction Sheet for 510317	1
	92970070	Warning and Contents Sheet	1
	92970085	Glovebox Mod. Template for 510317	1



**American  
Autowire**

www.americanautowire.com 856-933-0801

Classic Update Kit  
1966-77 Ford Bronco  
**510317**

92974029 Rev. 0.0 03/22/2024



**WARNING:** This harness is intended to be used in a modified vehicle. Please read this sheet thoroughly and be sure that you understand everything explained on it prior to opening any of the enclosed packages, or before attempting to install any of the components. Once this kit has been opened or a component installed, the kit is not returnable. Some early Broncos had rectangular holes in the firewall behind the engine and a small round hole in the upper driver side of the firewall. For your new AAW kit, you will need to open up the driver's side hole to 1 1/2" and you will need to make a new 1 1/2" hole on the passenger side as well. The center rectangular hole will not be used at all and should be closed up in some way. New grommets to line these two new 1 1/2" holes have been provided for you in the 510323 grommet and parts kit.

1. This kit should be used in a **MODIFIED** application only. **You will need to purchase a new plastic glovebox liner assembly** without the factory fusebox hole cut into it (these are available from various sources) as the new AAW fusepanel harness mounts inside the left hand side of the glovebox area where the factory dash speaker was originally located. **You cannot use a stock radio speaker when using this kit.**
2. This kit only supports the use of a higher current self-exciting 1 wire, or other style internally regulated alternator. An adapter may be necessary for certain applications. The use of a stock, low amperage alternator is seriously discouraged as they cannot handle the higher current requirements of updated ignition systems, electric fans, aftermarket A/C systems, stereo systems, air ride suspensions, and other power hungry accessories and will ultimately create performance issues with the system.
3. This kit **WILL NOT** support the use of a factory ammeter. All AAW kits are engineered to supply the optimum charge to the battery. To achieve this performance, we route our 6ga. charge wire directly from the alternator output terminal to the starter solenoid. Due to the path of the charge being altered from the stock configuration, the gauge can no longer see a charge vs. a discharge, so it will not work properly. When ammeters were originally used, most generator or alternator current outputs were rated at maximum of about 25-60 amps. Modified vehicles being built today typically utilize a 100 amp or higher output alternator. With these higher current units, ammeters, generally speaking, become a safety hazard. Ammeters are usually wired in parallel to the charging circuit, are typically unfused, and can short very easily causing a fire. A voltmeter is recommended as a good alternative.
4. This kit **IS NOT** set up with a resistance wire or a ballast resistor for a standard, points type ignition system. It is wired with a full 12 volt primary ignition feed that is hot in both the start and run positions. It will support HEI, MSD, other electronic ignition systems, as well as computerized Fuel Injection systems. If you wish to run a points type system, there are illustrations on the engine connection pages to do so. Extra parts that are not included in this kit will be required to complete that operation.



**510317**

## 510317 - Classic Update Series Kit 1966-77 Ford Bronco

This kit contains the following components:

<u>Bag</u>	<u>Part Number</u>	<u>Description</u>	<u>Quantity</u>
	500042	Floor Dimmer Switch	1
	500919	Practice Terminal Crimping Set	1
	510128	Ignition Switch	1
	510145	Fuse, Relay, and Flasher Kit	1
G	510318	Dash and Main Harness Kit	1
H	510319	Dash Cluster Kit	1
M	510320	Rear Body Kit	1
	510321	Headlight Switch	1
	510322	Wiper Switch	1
	510323	Grommet and Parts Kit	1
Z	510476	Alternator and Main Connection kit	1
	92970069	Instruction Sheet for 510317, 66-77 Bronco kit	1
	92970070	Warning and Contents Sheet	1
	92970085	Glovebox Mod. Template for 510317	1

Validate the kit contents with this component list. If there are any discrepancies with incorrect or missing parts, stop your installation and notify the supplier you purchased the kit from before proceeding



# 510317

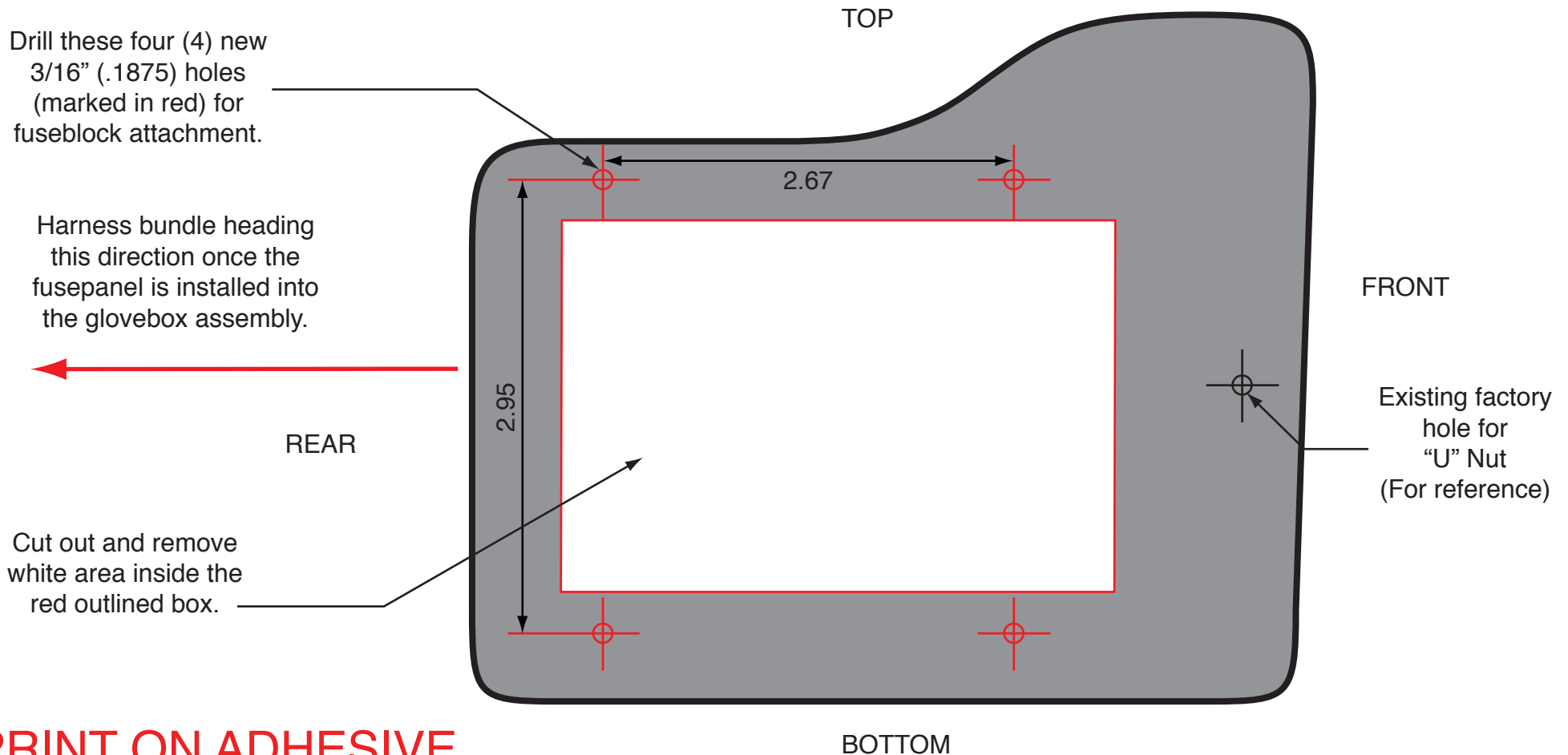

## PRINT ON ADHESIVE LABEL SHEET

1. You cannot use this harness with a stock radio dash speaker as the new AAW fusepanel mounts in the area where the original speaker was located.
2. You will need to purchase a new plastic glovebox liner assembly that does not have a stock fusebox hole in it to mount the new AAW harness into your vehicle.
3. Attach this template to the outside of the driver's side of the glovebox assembly (closest to where the production radio dash speaker was), cut out the white area bordered in red, and drill the four .1875 holes as marked on the template.
4. Once your rectangular opening has been cut out and your 4 new holes are drilled, place the new AAW fusepanel thru the opening and attach the fusepanel into that opening using the 4 locking nuts included/supplied in the loose piece parts kit of the 510317 dash/main harness with the harness bundle facing toward the rear of the glovebox as shown above.



**American  
Autowire**

www.americanautowire.com 856-933-0801

**92970085**

Rev 1.1 2/14/2017



# Classic Update Series

1966 - 1977 Ford Bronco

## START HERE !

PLEASE READ THIS BEFORE STARTING INSTALLATION !

This wiring kit is designed for ease of installation. Please read the guidelines below, BEFORE STARTING your installation to guarantee a successful job. Use an appropriate crimping tool which folds the wings of the open barrel terminals down into the wire as shown below. ALL TERMINALS THAT YOU INSTALL SHOULD BE PROPERLY SOLDERED. Our factory crimped terminations are installed by GM approved five ton presses, and soldering these terminations is not necessary. AAW offers a great terminal crimping video entitled "Proper Crimping Video". It can be viewed by visiting YouTube. Type the following address into your web browser to go directly to the video: [www.youtube.com/watch?v=8u\\_EkMsioMy](http://www.youtube.com/watch?v=8u_EkMsioMy).



AS THIS HARNESS IS DESIGNED FOR USE IN A MODIFIED TRUCK REQUIRING A HIGHER RATE OF CHARGE, IT DOES NOT SUPPORT THE USE OF A STOCK (ORIGINAL) ALTERNATOR OR GENERATOR. IT IS DESIGNED FOR USE WITH AN INTERNALLY REGULATED GM "SI" STYLE OR SINGLE WIRE STYLE ALTERNATOR. ADAPTERS (WHICH ARE NOT INCLUDED WITH THIS KIT) THAT ARE AVAILABLE FROM SEVERAL SOURCES WILL BE NECESSARY TO USE ANY ALTERNATOR OTHER THAN A 1 WIRE UNIT.

#### STEP 1: DISCONNECT YOUR BATTERY:

Disconnect the battery before installing the wiring kit to prevent any accidental shorting caused by loose bare wire ends.

#### STEP 2: START INSTALLING KIT:

This kit is broken down into individual steps that are identified by a letter printed on the instruction sheets visible through each bag. These letters are the order of operation for installing your kit. Start with bag letter G, then H, etc. The order of installation is shown below. Use this main instruction sheet, 92970069, to complete the installation process.

G - 510318 Dash Harness Kit  
H - 510319 Gauge Cluster Kit  
M - 510320 Rear Body Kit  
Z - 510476 Alternator and Main Power Connection Kit

#### STEP 3: RECONNECT YOUR BATTERY:

When you have completed the installation and are ready to reconnect the battery, make sure that the following electrical system grounds are in place:

- A. Battery is grounded to the ENGINE BLOCK.
- B. Battery is grounded to the frame.
- C. Engine block is grounded to the frame.
- D. Body is grounded to the frame.

#### STEP 4: CHECK ALL ELECTRICAL FUNCTIONS:

Any non-functioning items should be checked for proper installation. Any problems with your wiring and electrical circuit functions should be addressed to American Autowire Systems, Inc. as soon as possible to avoid any warranty problems.

If you have any questions concerning this or any of our products, please feel free to call us at 1-856-933-0801.

AMERICAN AUTOWIRE MAKES IT EASY !!

We carry many accessories for your 1966-77 Ford Bronco

p/n 510585  
OEM small terminal crimping  
tool (18-14 gauge)



p/n 510586  
OEM large terminal crimping  
tool (12-8 gauge)

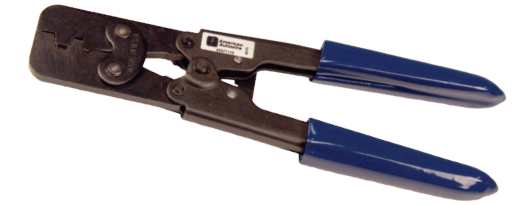

p/n 500918  
Ford Duraspark  
Ignition Harness

p/n 500802  
Ford Gen III Alternator Adapter

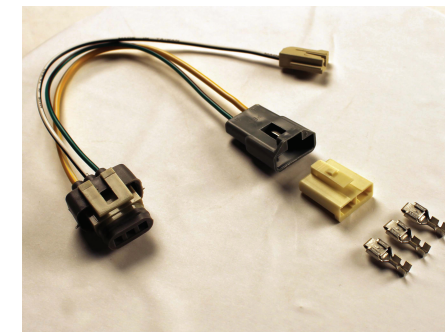

p/n R0067108  
OEM style non-stick harness tape



[www.americanautowire.com](http://www.americanautowire.com) 856-933-0801

Classic Update Series

1966-1977  
Ford Bronco

# 510317

© COPYRIGHT 2004 American Autowire / Factory-Fit  
Used with express permission of  
American Autowire / Factory-Fit

92970069 Rev. 9.0 1/26/2018

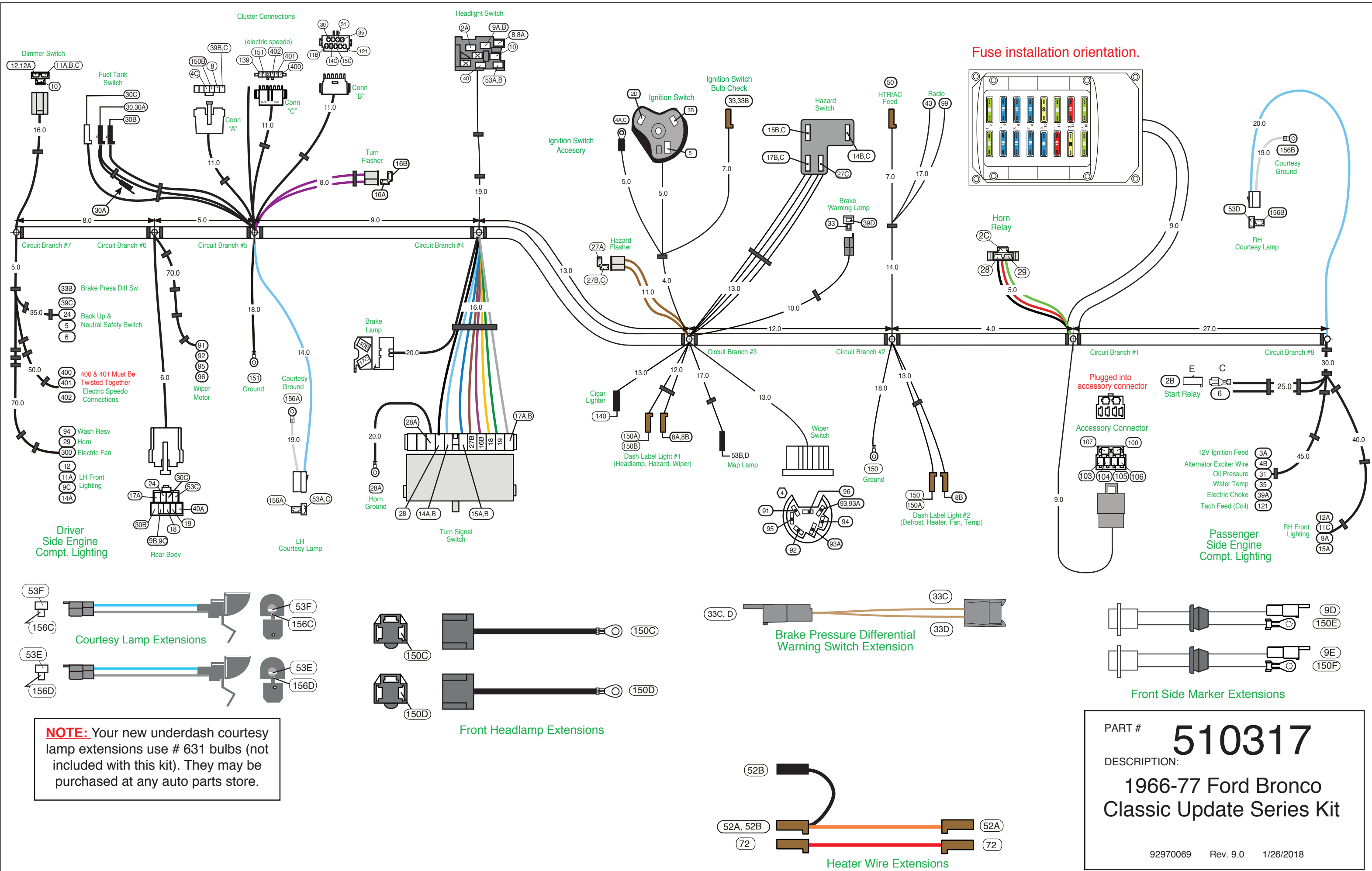

**NOTE:** Your new underdash courtesy lamp extensions use # 631 bulbs (not included with this kit). They may be purchased at any auto parts store.

PART # **510317**  
 DESCRIPTION:  
**1966-77 Ford Bronco Classic Update Series Kit**  
 92970069 Rev. 9.0 1/26/2018

**Main Fuse Panel Installation Instructions**

The fuse box on this Main Fuse Panel harness is designed to be mounted under the dash to the outside of LH side the glovebox assembly as seen in the photo on page 11. The enclosed representation of the main dash harness shows each circuit branch and identifies each connection by its color and function. Follow this drawing and detail drawings on pages 9 and 10 for the individual circuit connections.

**Circuit Branch 8 - RH Front Lighting connections**

See page 9, Figure A for typical connections. For loose piece terminals and connectors, see parts kit # 510323.

**NOTE:** We have provided you with Terminals B and Connector F to assemble onto your existing parking lamps so that you can connect them onto the new AAW wire leads 9A and 15A below coming from the dash/main harness 510318 to complete your RH parking and directional circuits.

Wire #	Wire color	Printing	Procedure
15A	Dark Blue	Right Front Turn	Route to the right front parking lamp area. This wire should ultimately be mated with the high intensity filament (original white with a blue stripe wire) of the RH front parking lamp using terminals J and connector H as shown on page 9, Figure A.
9A	Brown	Park Lights	(66-69) Route to the right front parking lamp area. This wire should ultimately be mated with the low intensity filament (original brown wire) of the RH front parking lamp using terminals J and connector H as shown on page 9, figure A. (70-77) Route to the right front side marker lamp area cut to length, double with the cutoff portion, install terminal C and plug into connector E. Install 1 sidemarker extension assembly from page 2 through the inner fender area securing the grommet into the pass through hole and plug the extension onto connector E. Attach the black wire on the side marker extension to a good chassis ground. Route the loose end of this brown wire over to the RH parking lamp area and connect to the RH parking lamp. This wire should ultimately be mated with the low intensity filament (original brown wire) of the RH front parking lamp using terminals J and connector H as shown on page 9, figure A.
11C	Light Green	Headlight-Hi Beam	Select the light green Headlight Hi Beam wire 11C and tan Headlight Low Beam wire 12A. Route these wires to the RH headlight and using supplied terminals A as found in kit 510323, connect these wires into one of the front headlight extension assemblies (as shown on page 2) found on the dash/main wire kit, 510318. Specific connection and orientation for this process can be found in the diagram on page 9, Figure A.
12A	Tan	Headlight-Low Beam	

**Circuit Branch 8 - Eng., Alt. & Power connections**

See pages 9 and 10, Figures A and D for typical connections. For loose terminals/connectors, see parts kit # 510323.

Wire #	Wire color	Printing	Procedure
6	Purple	Starter Solenoid-S	Connect the end that comes out with the heavy red power wire 2B to the "S" terminal on your starter solenoid. (See Figure A).
2	Red	(no printing)	Use the 6ga red wire, MegaFuse, boot, ring terminals, and shrink tube from the 510476 kit. Route from the MegaFuse to the alternator cut to length and apply ring terminals, shrink tube, boot then connect per the instructions in the 510476 Alternator and Main Power Connection kit.
2B	Red	12 V Battery	Route the red 12V Battery wire (circuit 2B) which is in the Dash Harness, to the Megafuses (see Figure D on page 10) and cut to length. Use ring terminal and shrink tubing from 510476 kit. Connect as shown on page 10.
4B	Brown	Alternator Ign	<b>NOTE: If you are using a one wire alternator, the 4B wire will not be used, so tape it back to the trunk of the harness.</b> This wire is the exciter wire for your Ford alternator / voltage regulator. It DOES NOT have any resistance on it as many of the Ford regulators already have an internal resistor. If the Ford or other alternator / regulator that you are using needs a resistor in-line on the feed wire, you will have to supply it per the specs of that alternator (AAW recommends a GEN 3 Internally Regulated [AAW p/n 500802 available separately] or 1 wire unit).
3A	Pink	Ignition Feed - coil	This is your 12 volt switched power source for the distributor/coil. This can be connected directly to the "bat" terminal on a typical HEI distributor, to a ballast resistor as in a points type distributor, or be used as the ignition power source for an aftermarket ignition module such as an MSD or "Duraspark" module. See the installation instructions for the type of distributor you are using for specific connection requirements. If you are using a GM style HEI distributor, terminal C and connector Q have been provided to make that connection (See page 9, Figure A for some examples)
31	Dark Blue	Oil Pressure Sender	Connect to the oil pressure sender (See page 9, Figure A for some examples).
35	Dark Green	Water Temp Sender	Connect to the temperature sender (See page 9, Figure A for some examples).
39A	Tan	Electric Choke	On carbureted cars, connect to the electric choke terminal.
121	White	Coil - Tach	This can be connected directly to the tach terminal on a typical HEI distributor, to the negative side of the coil, or a tach connection in an aftermarket ignition module such as an MSD module. If you are using a GM style HEI distributor, terminal B and connector R have been provided to make that connection (See page 9, Figure A for some examples).

**Circuit Branch 8 - Underdash Connections**

Wire #	Wire color	Printing	Procedure
RH Courtesy Connection			
53B	Lt. Blue	12v Ctsy Sw	Plug in 1 Courtesy lamp extension (as found on page 2 of this instruction set) to complete this circuit.
156B	White	Ctsy Ground	Switched 12 volt power for RH underdash courtesy lamp.
			RH underdash courtesy ground.

**Circuit Branch 1 - Underdash Connections**

Wire #	Wire color	Printing	Procedure
Horn Relay			
2C	Red	12v Bat	Plug the horn relay (found in the 510145 fuse kit) into this connector.
28	Black	Relay Ground	12 volt battery feed.
29	Green	Horn	Relay ground circuit (to steering column).
			Triggered 12 volts to horn.
Accessory Wire Connector			
			Use the provided connector J and terminals as power leads for the following:
Fuse	Rating		
103	Tan	Fuel Pump	FUSED 12 volt IGNITION feed for fuel pump (or another fused ignition circuit)
104	Orange	Power Seats	FUSED 12 volt BATTERY feed for power seats (or another fused battery circuit)
105	Red	Power Locks	FUSED 12 volt BATTERY feed for power door locks (or another fused battery circuit)
100	Red	CB Radio	FUSED 12 volt BATTERY feed for cruise control (or another fused battery circuit)
106	Pink	Power Window	FUSED 12 volt ACCESSORY feed for power windows (or another fused accessory circuit)
107	Orange	Spare Battery	FUSED 12 volt BATTERY feed (for any application)

**Fuse installation orientation.**

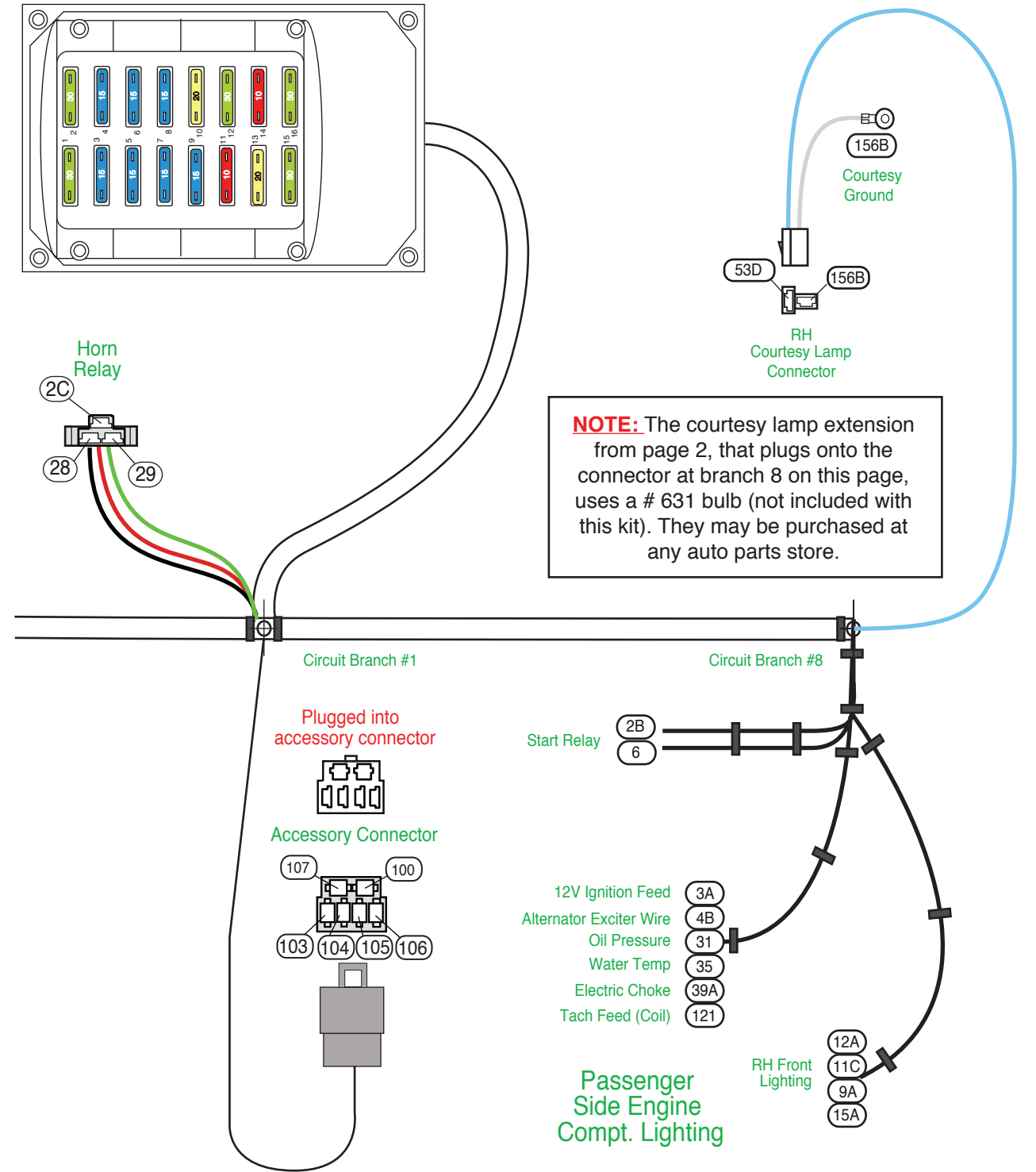

www.americanautowire.com 856-933-0801

PART # **510317**  
 DESCRIPTION:  
**1966-77 Ford Bronco Classic Update Series Kit**

92970069 Rev. 9.0 1/26/2018



Main Fuse Panel Installation Instructions

**Circuit Branch 2 - Underdash Connections**

Wire #	Wire color	Printing
Radio/ Clock Connections		
43	Tan	Radio
99	Yellow	Clock Battery
Heat and A/C Feed		
50	Brown	Heater AC Feed
Dash Label Lamps		
8B	Gray	Dash Lights
150 & A	Black	Ground
Ground Lead		
150	Black	Ground

**Procedure**

12v fused accessory feed for radio "on/off" power.  
 12v fused battery feed for radio clock and memory or dash clock assembly.  
 This wire will plug onto your stock heater switch or can be used as the "on/off" power source for aftermarket A/C.  
 12v switched feed for "on/off" power to your stock heater switch or aftermarket heat and A/C.  
 These wires are used to illuminate the Defroster, Heater Fan, and Temperature labels on the dash.  
 Feed out to dash label lamp connections.  
 Chassis ground for dash label lamp connections.  
 Attach this wire to a good known chassis ground. (Note: Do not attach this wire with the 151 wire on page 5)  
 Chassis ground for instrument cluster dash label lamp connections.

**Circuit Branch 3 - Underdash Connections**

Wire #	Wire Color	Printing
Hazard Flasher		
27A,B,C	Brown	Turn Sw Hazard
Ignition Switch		
2D	Red	12v Bat
3B	Pink	Ignition Feed
4A, C	Brown	Ignition Sw Accessory
5	Purple	Neutral Safety Switch
33, 33B	Tan	Brake Light/Switch

**Procedure**

Plug one of the flasher cans (found in the 510145 fuse kit) into this connection.  
 Hazard flasher leads.  
 Plug this main connector onto the ignition switch 510128.  
 Battery feed to the ignition switch.  
 Ignition feed to fuse panel and ignition system.  
 Accessory feed to fuse panel and alternator regulator exciter connection.  
 Start feed to neutral safety switch.  
 This connector plugs onto the ground blade on the 510128 ignition switch and is the bulb check ground for the brake warning circuit.  
 This is for the 1967-72 Bronco dash mounted 4 Way Hazard Flasher Warning Switch. If your truck is a 1967-72 unit, plug this connector onto your dash mounted hazard flasher switch assembly. If your truck is a 1966 or a 1973-77, this connector will not be used and can just be left hanging under the dashboard. If your truck is a 1973-77 unit, the hazard flasher switch is mounted in the steering column turn signal switch and will be addressed on page 5 of this instruction sheet. If your truck is a 1966, there was no provision for hazard flashers in that truck.  
 LH output for hazard switch.  
 RH output for hazard switch.  
 Hazard flasher power.  
 12v input/override from brake switch to hazard switch.

**Hazard Flasher Switch**

14B,C	Lt. Blue	Left Front Turn
15B,C	Dk. Blue	Right Front Turn
27C	Brown	Turn Sw Hazard
17B,C	White	Brake Sw

**Brake Warning Lamp**

**NOTE:** Your original dash mounted warning lamp uses a unique socket assembly that must be re-used. You will need to cut the purple and red with yellow stripe wires about 4 inches from the back of the original socket and crimp new terminals B that we have provided for you onto those wires. The finished wires must then be plugged into connector F so that the original red with yellow stripe wire mates with the AAW pink "12V ign" wire and the original purple wire mates to the AAW tan "brake light/switch" wire. The necessary terminals B and connector F to complete this task can be found in the loose piece kit of the 510318 dash kit. Once completed, you will plug this assembly into the mating dash connection at branch 3 of the 510318 dash harness to complete this circuit.

33	Tan	Brake Light/Switch
39D	Pink	12v Ignition

Plug this connection onto your original lighter socket assembly.  
 12v battery feed for the cigarette lighter.

**Dash Label Lamps**

8A, 8B	Gray	
150A, B	Black	Ground

These wires are used to illuminate the Headlamp, Hazard, and Wiper labels on the dash.  
 Feed out to dash label lamp connections.  
 Chassis ground for dash label lamp connections.

**Map Light Switch**

53B, D	Lt. Blue	12v Ctsy Sw
--------	----------	-------------

Plug this connector onto your original map lamp switch assembly.  
 Switched 12 volt power from lighting switch to map lamp assembly.

**Wiper Switch**

93, 93A	White	Wiper Feed
93A	White	Wiper Feed
91	White	(no printing)
92	Dk. Blue	(no printing)
94	Dk. Green	(no printing)
95	Black	(no printing)
96	Red	(no printing)

Plug this connector onto the new 510322 wiper switch assembly.  
 12v fused feed for wiper switch assembly.  
 12v fused feed for washer pump lead. (for 1966, connect to one side of your washer pump push button switch)  
 Switched 12v lead out for wiper low speed.  
 Switched 12v lead out for wiper high speed.  
 Switched 12v lead out for washer pump. (for 1966, connect to one side of your washer pump push button switch)  
 Wiper motor park.  
 Wiper motor low park.

**Circuit Branch 4 - Underdash Connections**

Wire #	Wire Color	Printing
Lighting Switch		
2A	Red	12v Bat
8, 8A	Gray	Dash Lights
9A, B	Brown	Park Lights
10	Yellow	Dimmer Sw Feed
40	Orange	12v Batttery Fused
53A, B	Lt. Blue	12v Ctsy Sw

**Procedure**

Plug this connector onto lighting switch 510321.  
 Unfused 12v battery feed to the lighting switch for headlamps, tail lmaps, and dash illumination lamps.  
 Feed out to dash illumination lamps at cluster and dash label lamps.  
 Feed out to RH front parking and rear tail lamps at the rear body connector.  
 Feed to headlight dimmer switch for headlights.  
 Secondary fused 12v battery feed to lighting switch for courtesy and dome lamps.  
 Switched 12 volt power from lighting switch to dome, underdash courtesy lamps, and map lamp feed.

**Brake Switch Connections**

40B	Orange	12v Battery Fused
17C	White	Brake Switch

Plug this on to your stock brake lamp switch (In the event that you own a 1966 Bronco, these two wires will need to be extended out through the firewall to be plugged onto your Brake Switch at the master cylinder)  
 Battery fused 12v feed to the brake switch.  
 12v feed out of the brake switch to the turn signal switch.

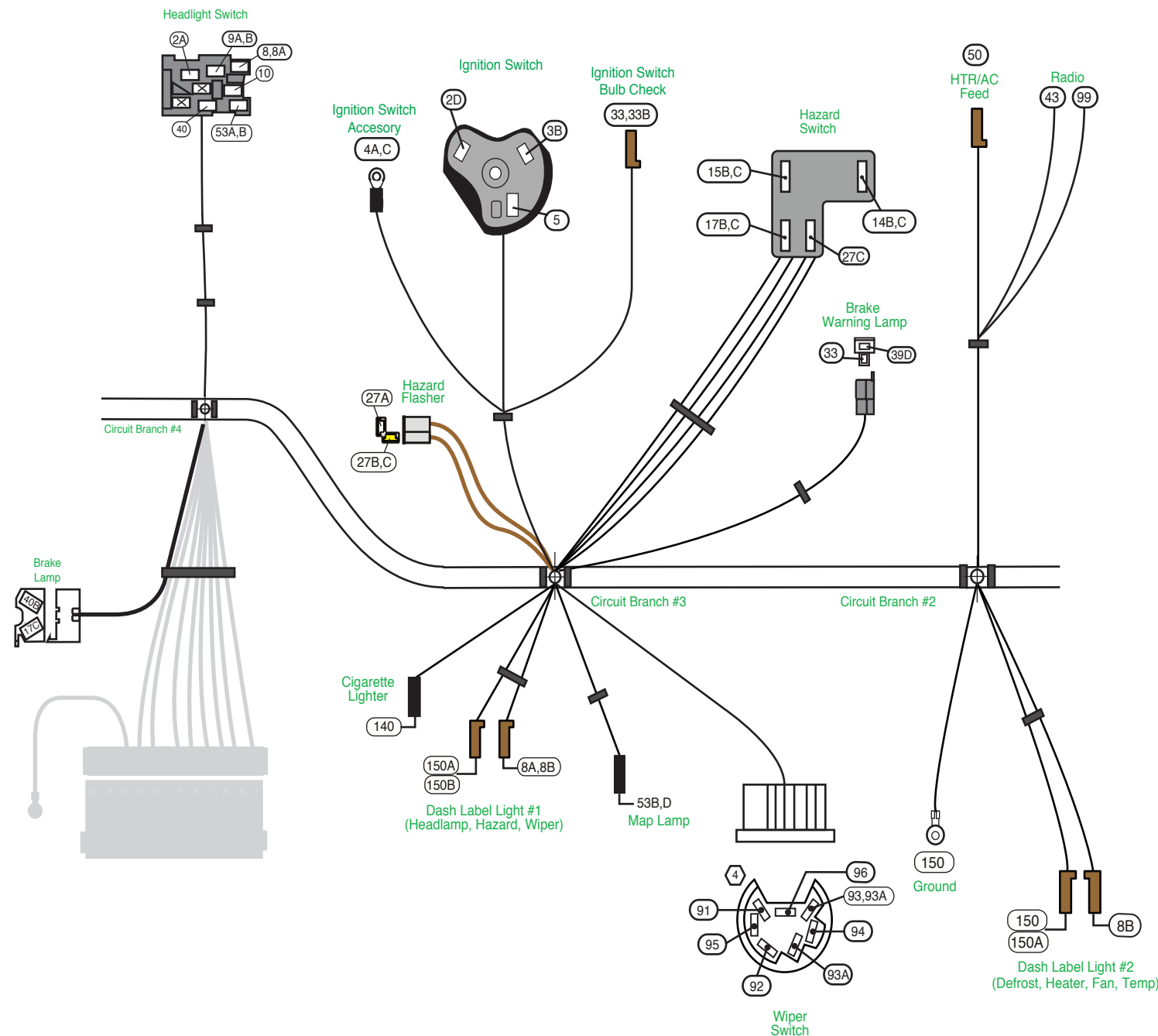

www.americanautowire.com 856-933-0801

PART # **510317**  
 DESCRIPTION:  
**1966-77 Ford Bronco  
 Classic Update Series Kit**

92970069 Rev. 9.0 1/26/2018

Procedure

**Circuit Branch 4 - Underdash Connections**

Wire # Wire Color Printing  
Turn Signal Switch Connection

14A, B	Lt. Blue	Left Front Turn
15A, B	Dk. Blue	Right Front Turn
16B	Purple	Turn Switch Feed
17A	Lt. Blue	Third Brake Lt.
17B	White	Brake Sw
18	Yellow	Left Rear Turn
19	Dk. Green	Right Rear Turn
27B	Brown	Turn Sw Hazard
28	Black	Horn Relay Ground
28A	Black	Horn Relay Ground

Procedure

Plug into steering column turn signal connection. If you are using a stock Ford steering column on your vehicle, refer to Diagram 'A' and "Table A - AAW turn signal wires to stock turn signal switch wires" on page 8 for proper mating directions. This kit is designed to function with a GM style turn signal switch. Our connector mates to a 3 7/8 inch long plug used on 1969-1974 GM, IDIDIT, and many other aftermarket steering columns. Starting from 1975 on up, the GM switch changed and began using a 4 1/4 inch connector. That connector is from the same family and uses the same terminals. By using the supplied mating connector (L) and terminals (M) located in the loose piece kit bag of this dash harness (510318), it is easy to adapt any steering column to the kit. The function of the wires are as follows:

LH front turn signal feed out to front light and dash cluster connections.  
RH front turn signal feed out to front light and dash cluster connections.  
Turn signal 12v feed into column from flasher.  
12v feed for third brake light to rear body connector.  
12v input from brake switch to turn switch for rear brake lights.  
LH rear turn signal feed out to rear body connection.  
RH rear turn signal feed out to rear body connection.  
Hazard switch 12v feed into column from flasher.  
Steering column horn ground to horn relay.  
Steering column horn ground to horn relay. **Attach this wire to a good known chassis ground.**

**Circuit Branch 5 - Underdash Connections**

Wire # Wire color Printing  
LH Courtesy Connection  
53A,C Lt. Blue 12v Ctsy Sw  
156A White Ctsy Ground

Procedure

Plug in 1 Courtesy lamp extension (as found on page 2 of this instruction set) to complete this circuit. Switched 12 volt power for LH underdash courtesy lamp and feed to RB harness for dome lamp. LH underdash courtesy ground.

Ground Lead  
151 Black/White Speedo Ground

Attach this wire to a good known chassis ground. (Note: Do not attach this wire with the 150 wire on page 4) Chassis ground for instrument cluster electric speedo connection.

Flasher  
16A, B Purple Turn Switch Feed

Plug the other of the flasher cans (found in the 510145 fuse kit) into this connection. Turn signal flasher leads.

Instrument Cluster Connections

4C	Brown	(no printing)
8	Gray	Dash Lights
11B	Lt. Green	Hi Beam Indicator Light
14C	Lt. BLue	Left Turn Ind
15C	Dk. Blue	Right Turn Ind
30	Tan	Gas Gauge
31	Dk. Blue	Oil Pressure
35	Dk. Green	Temp Sender
39B,C	Pink	12v Ign Fused
121	White	Coil Tach
139	Pink/White	Speedo Power
150B	Black	Ground
151	Black	Ground
400	Yellow	VSS Ground
401	Purple	VSS Signal
402	Purple/White	VSS Power

These connections will plug into the Cluster Connection Kit, 510319. Specific connections are addressed in that kit.  
12v accessory feed to the cluster for the constant voltage unit for use with stock gauges.  
Feed out from the lighting switch for dash illumination lamps to cluster connection.  
12v feed to dash cluster for high beam indicator lamp to cluster connection.  
12v feed to dash cluster for left front turn indicator lamp to cluster connection.  
12v feed to dash cluster for right front turn indicator lamp to cluster connection.  
Fuel sender signal from rear body harness or dual tank switch connection to cluster connection.  
Oil pressure signal from engine harness lead to cluster connection.  
Temperature sender signal from engine harness lead to cluster connection.  
Fused 12v Ignition feed to cluster connection for any aftermarket 12v gauges, then on to the back up switch.  
Tach sender signal wire from engine harness lead to the cluster connection.  
Fused 12v Ignition feed for electric speedometer to cluster connection.  
Gauge cluster ground to cluster connection.  
Electric speedometer ground to cluster connection.  
VSS ground from engine harness to cluster connections for electric speedometer.  
VSS signal from engine harness to cluster connections for electric speedometer.  
VSS 12v fused power from cluster connections to engine harness leads for electric speedometer.

Fuel Tank Switch

30	Tan	Gas Gauge
30A	Tan	Gas Gauge
30B	Tan	Gas Gauge
30C	White	Gas Gauge Aux Tank

If your truck has dual fuel tanks, plug the three fuel tank switch connectors onto your selector switch as shown in Figure F at the top of this page, then install the tank selector switch back into your dashboard. This connection will allow you to switch your gas gauge from one tank sending unit to the other and get an accurate reading. If your truck only has a single fuel tank, plug the tan 30B wire with the black connector into the mating black connector on the tan 30A wire. No other connections are necessary.  
Gas gauge feed to the dash cluster connector.  
Gas gauge jumper feed wire from dash cluster connector to main sending unit feed wire in rear body connector.  
Main gas gauge sending unit feed wire to dual tank switch or to tan 30A jumper feed wire from rear body connector.  
Auxiliary gas gauge sending unit feed wire to dual tank switch from rear body connector.

**Circuit Branch 6 - Underdash Connections**

Wire # Wire Color Printing  
Rear Body Connection

9B,C	Brown	Rear Running Lights
17A	Lt. Blue	Third Brake Light
18	Yellow	Left Rear Turn
19	Dk. Green	Right Rear Turn
24	Lt. Green	Back Up Lt Sw
30B	Tan	Gas Gauge
30C	Tan	Gas Gauge Aux Tank
40A	Orange	12v Battery Fused
53C	Lt. Blue	12v Ctsy Sw

Procedure

This connector will plug into the Rear Body Kit, 510320. Specific connections are addressed in that kit. These wires will pass out to the engine bay through the LH driver's side firewall grommet as seen on page 10, Figure C.  
Feed out from headlight switch for tail and tag lamps and feed out to the LH front parking lamp.  
Feed from the brake lamp switch for optional 3rd brake lamp.  
Feed out to the LH rear stop and turn lamp from the turn signal switch.  
Feed out to the RH rear stop and turn lamp from the turn signal switch.  
Feed out to the back up lamps (if so equipped) from the back up switch.  
Main fuel tank sender signal wire between the rear body and cluster connections.  
Auxiliary fuel tank sender signal wire between the rear body and cluster connections.  
12v battery feed for LED lamps.  
12v switched courtesy feed from the lighting switch for the dome lamp.

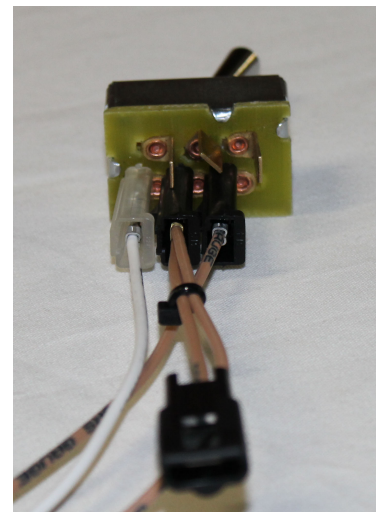
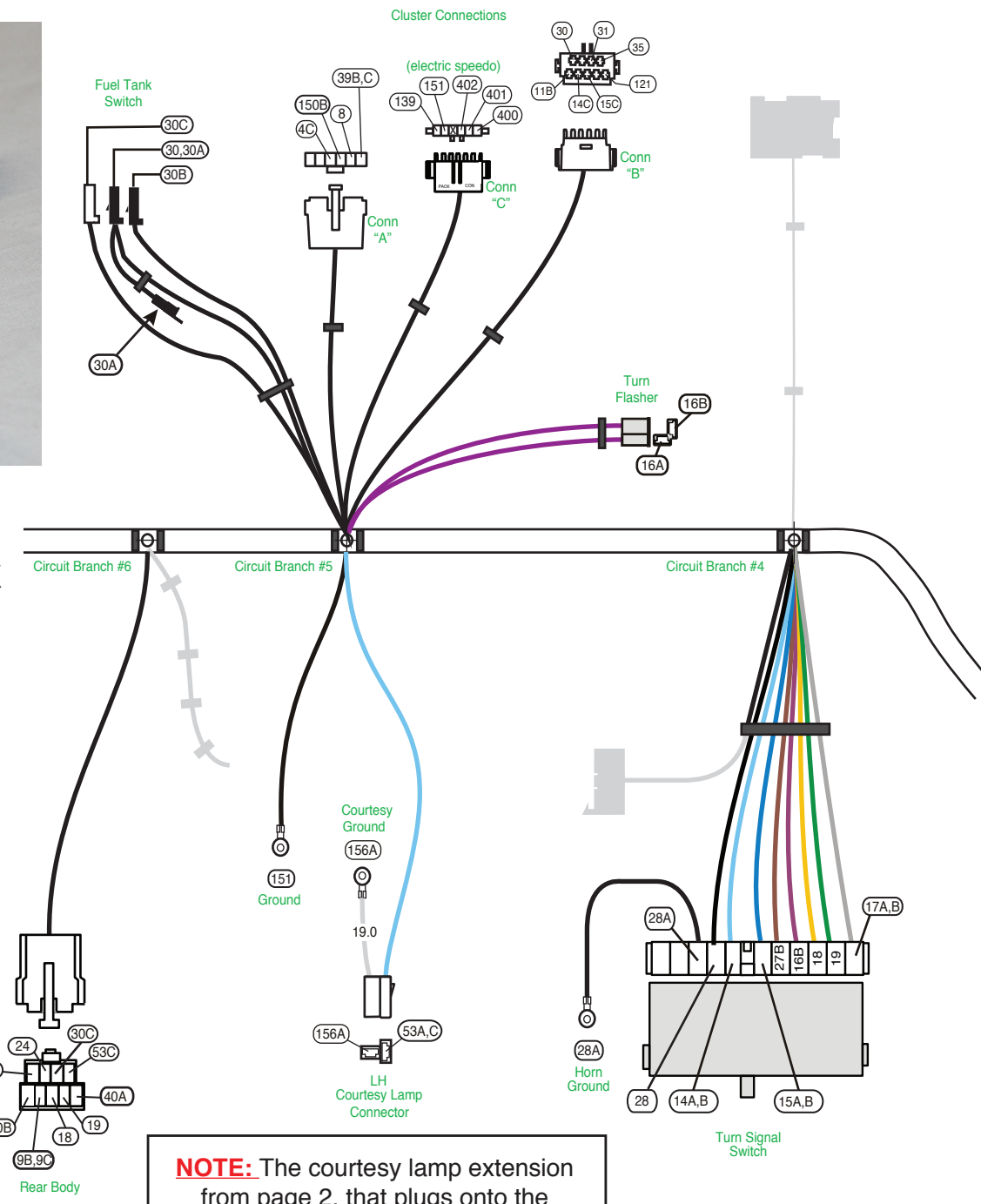

Figure "F"  
Dual fuel tank  
switch  
connection



**NOTE:** The courtesy lamp extension from page 2, that plugs onto the connector at branch 5 on this page, uses a # 631 bulb (not included with this kit). They may be purchased at any auto parts store.



www.americanautowire.com 856-933-0801

PART # **510317**  
DESCRIPTION:  
**1966-77 Ford Bronco  
Classic Update Series Kit**  
92970069 Rev. 9.0 1/26/2018

TYPICAL BLADE TYPE GAUGE CONNECTIONS

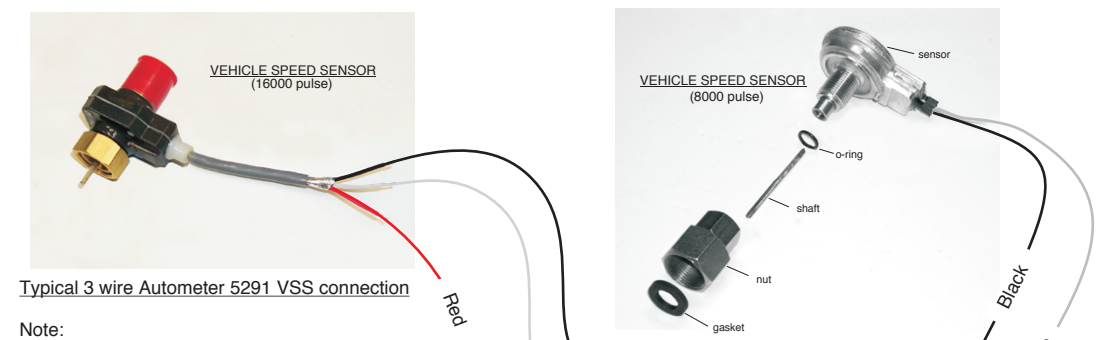
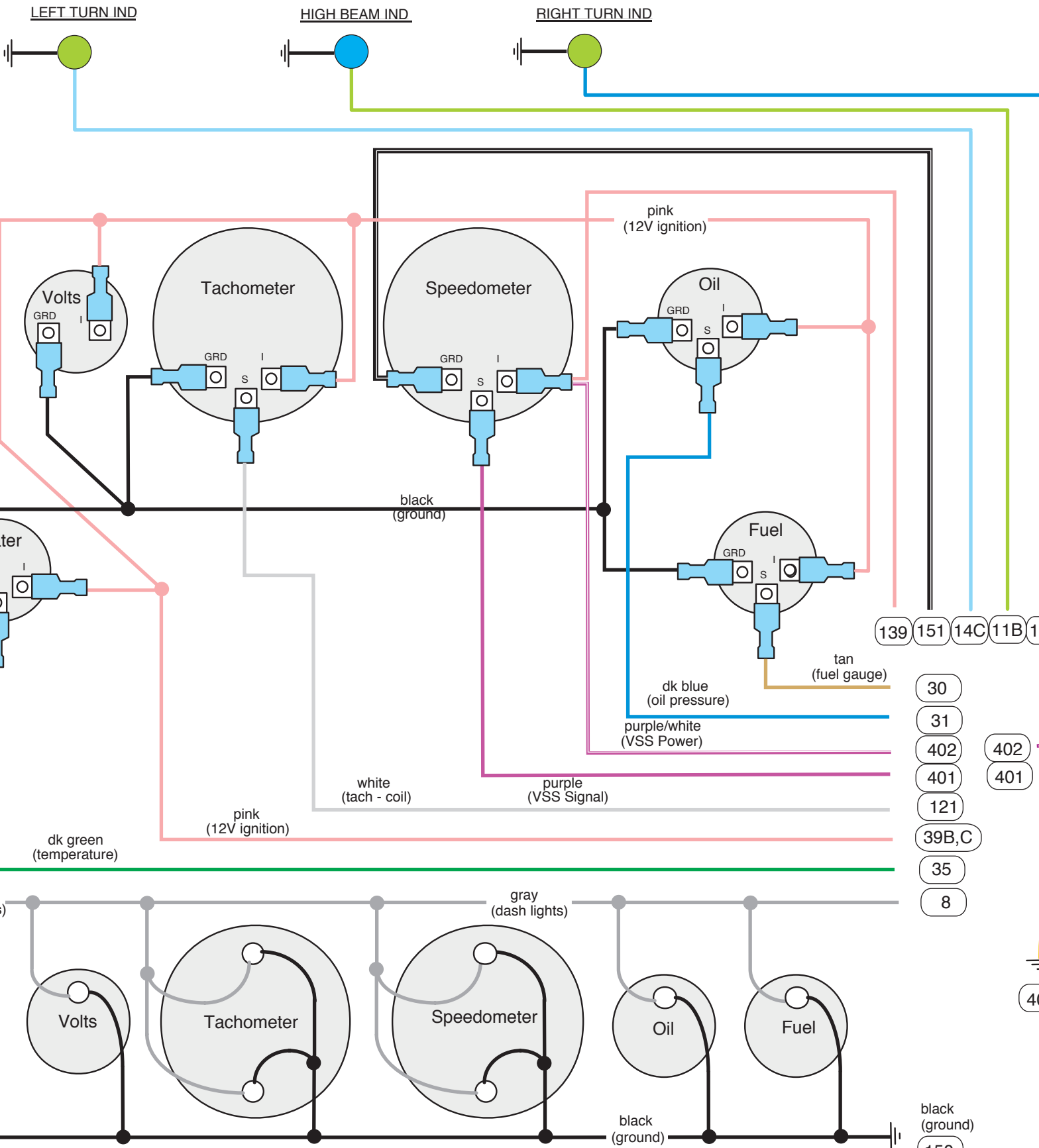

Typical 3 wire Autometer 5291 VSS connection  
 Note: This VSS requires a lead wire from the red wire to a 12 volt ignition source. This wire is not included in the kit.

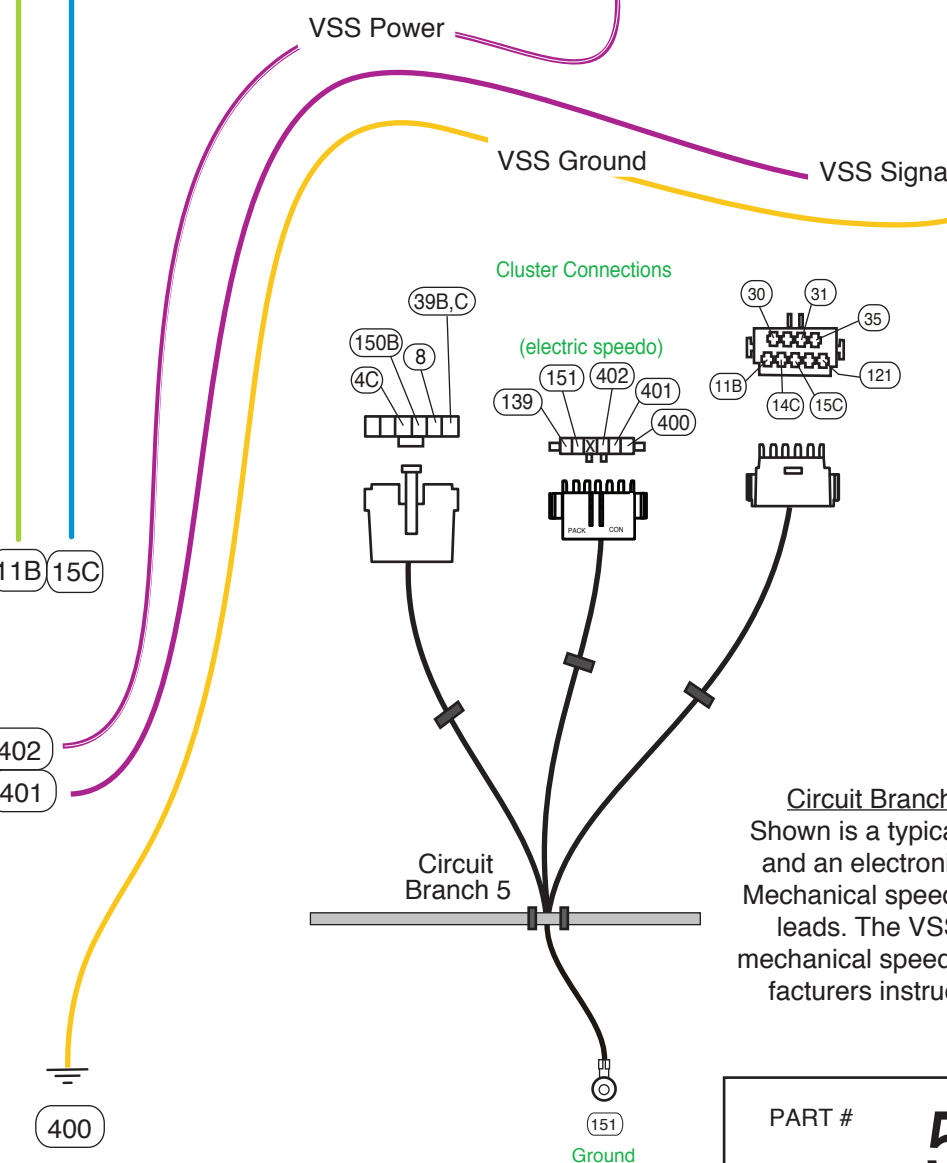

Note: Your VSS Signal and Ground wires have been twisted together from the factory and must remain this way to shield out any outside electrical interference that may create an issue with the proper operation of your electric speedometer.

Circuit Branch 5 - Instrument Cluster Wiring  
 Shown is a typical installation with electric gauges and an electronic speedometer and tachometer. Mechanical speedometers will only require the light leads. The VSS lead wires can be ignored for mechanical speedometers. Always check the manufacturer's instructions for specific requirements.



www.americanautowire.com 856-933-0801

PART # **510317**  
 DESCRIPTION:  
 1966-77 Ford Bronco  
 Classic Update Series Kit

92970069 Rev. 9.0 1/26/2018



**Circuit Branch 6 - Underdash Connections**

Wire # Wire Color Printing  
Wiper Motor Wire Leads

91	White	(no printing)
92	Dk. Blue	(no printing)
95	Black	(no printing)
96	Red	(no printing)

**Procedure**

Route these four wires over to the drivers side windshield frame area, then up through the windshield frame to the wiper motor. Connect these wires to your wiper motor assembly being certain to maintain the color continuity between the new wires on the AAW harness and the original wires (IE: white to white, red to red, etc.) on your wiper motor assembly.  
Switched 12v lead out for wiper low speed.  
Switched 12v lead out for wiper high speed.  
Wiper motor park.  
Wiper motor low park.

**Circuit Branch 7 - Underdash Connections**

Wire # Wire Color Printing  
Dimmer Switch  
10 Yellow Dimmer Switch Feed  
11A,B,C Light Green Headlight Hi Beam  
12, 12A Tan Headlight Low Beam

**Procedure**

Plug this connector onto the new 500042 dimmer switch assembly.  
12v Feed from H/L switch.  
Switched 12v from dimmer to LH and RH high beam lamps, and to the dash cluster connector for the indicator lamp.  
Switched 12v from dimmer to LH and RH low beam lamps.

**Circuit Branch 7 - LH Front Lighting Connections**

See page 10, Figure C for typical connections. For loose piece terminals and connectors, see parts kit # 510323.

**NOTE:** We have provided you with Terminals B and Connector F to assemble onto your existing parking lamps so that you can connect them onto the new AAW wire leads 9C and 14A below coming from the dash/main harness 510318 to complete your LH parking and directional circuits.

Wire # Wire color Printing  
14A Light Blue Left Front Turn

**Procedure**

Route to the left front parking lamp area. This wire should ultimately be mated with the high intensity filament (original green with a white stripe wire) of the LH front parking lamp using terminals J and connector H as shown on page 10, figure C.  
(66-69) Route to the left front parking lamp area. This wire should ultimately be mated with the low intensity filament (original brown wire) of the LH front parking lamp using terminals J and connector H as shown on page 10, figure C.  
(70-77) Route to the left front side marker lamp area cut to length, double with the cutoff portion, install terminal C and plug into connector E. Install 1 sidemarker extension assembly from page 2 through the inner fender area securing the grommet into the pass through hole and plug the extension onto connector E. Attach the black wire on the side marker extension to a good chassis ground. Route the loose end of this brown wire over to the LH parking lamp area and connect to the LH parking lamp. This wire should ultimately be mated with the low intensity filament (original brown wire) of the LH front parking lamp using terminals J and connector H as shown on page 10, figure C.  
Select the light green Headlight Hi Beam wire (11A) and tan Headlight Low Beam wire (12). Route these wires to the LH headlight and using supplied terminals A as found in kit 510323, connect these wires into one of the front headlight extension assemblies (as shown on page 2) found on the dash/main wire kit, 510318. Specific connection and orientation for this process can be found in the diagram on page 10, Figure C.

11A Light Green Headlight-Hi Beam  
12 Tan Headlight-Low Beam

**Circuit Branch 7 - Various Underhood connections**

See page 10, Figures C and E for typical connections. For loose terminals and connectors, see parts kit # 510323.

Wire # Wire color Printing

**Procedure**

**Back Up and Neutral Safety Switch Connections**

On a stock Bronco, the original back up and/or neutral safety switch can be found at the base of the steering column out under the hood of the truck in the engine bay. If your truck has a manual transmission, connect the 5 and 6 wires together to complete the starter circuit. A typical aftermarket connection for your neutral safety and back up switch can be found on page 10, Figure E.  
Switched feed from back up lamp switch to rear body connection.  
12v ignition feed to back up lamp switch.  
12v feed from solenoid post on the ignition switch to neutral safety switch.  
12v starter solenoid feed out from the neutral safety switch to engine connections at branch 8.

24	Lt. Green	Back Up Lt Sw
39C	Pink	12v Ign Fused
5	Purple	Neutral Safety Sw
6	Purple	Starter Solenoid

**Electric Speedo Connections**

**(NOTE: Wires 400 and 401 must remain twisted together)**

400	Yellow	VSS Ground
401	Purple	VSS Signal
402	Purple/White	VSS Power

Connect to the Vehicle Speed Sensor ground lead (see page 6 for typical connection).  
Connect to the Vehicle Speed Sensor signal lead (see page 6 for typical connection).  
Connect to the Vehicle Speed Sensor power lead if using a 3 wire sender (see page 6 for typical connection).

**Horn Connection**

29	Dark Green	Horn
----	------------	------

Connect to the horn power terminal. NOTE: If your horn has a separate ground terminal, you must supply the wire for this ground terminal as it is not included in the kit.

**Electric fan Connection**

300	Orange	Electric Fan
-----	--------	--------------

This is the 12 volt ignition feed to connect to the trigger wire on your electric fan relay (relay not supplied with this kit).

**Windshield Washer Connection**

94	Dark Green	(no printing)
----	------------	---------------

This is the 12v feed from the wiper switch inside the truck out to the washer pump assembly under the hood.

**Brake Pressure Differential Switch**

**(NOTE:)** We have provided you with the connection to the original Ford brake warning switch in the form of a wire extension assembly (wires 33C, D on page 2 of this instruction sheet). You will plug this extension onto wire 33B, below.

33B	Tan	Brake Switch
-----	-----	--------------

Route this wire to the brake warning switch area near the master cylinder, cut to length, install terminal B, plug into connector E as shown on page 10, figure C, then plug this wire into wire extension assembly 33C, D (from page 2 of this instruction sheet) to complete your brake warning circuit.

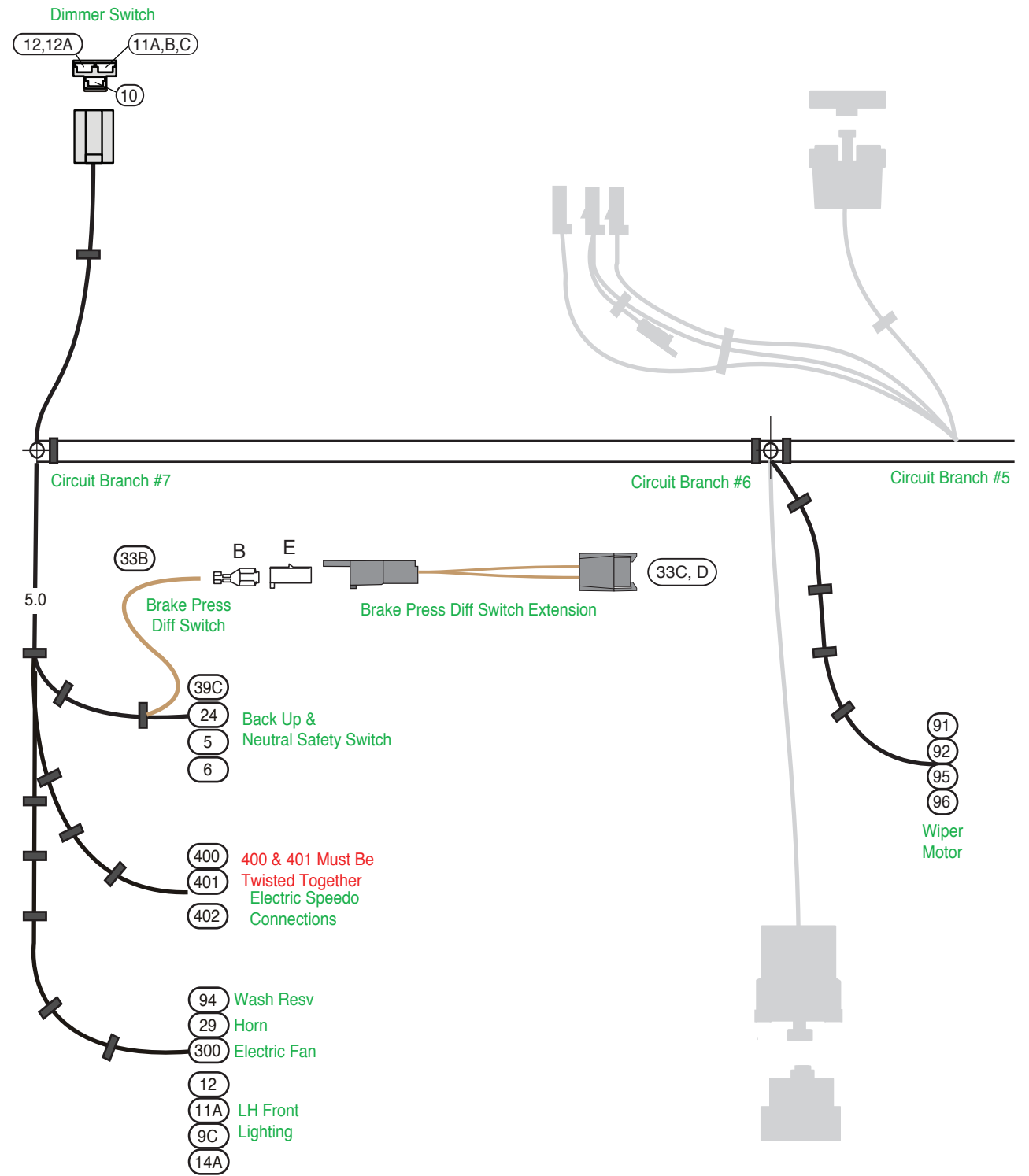

Driver Side Engine Compt. Lighting



www.americanautowire.com 856-933-0801

PART # **510317**  
DESCRIPTION:  
**1966-77 Ford Bronco Classic Update Series Kit**  
92970069 Rev. 9.0 1/26/2018

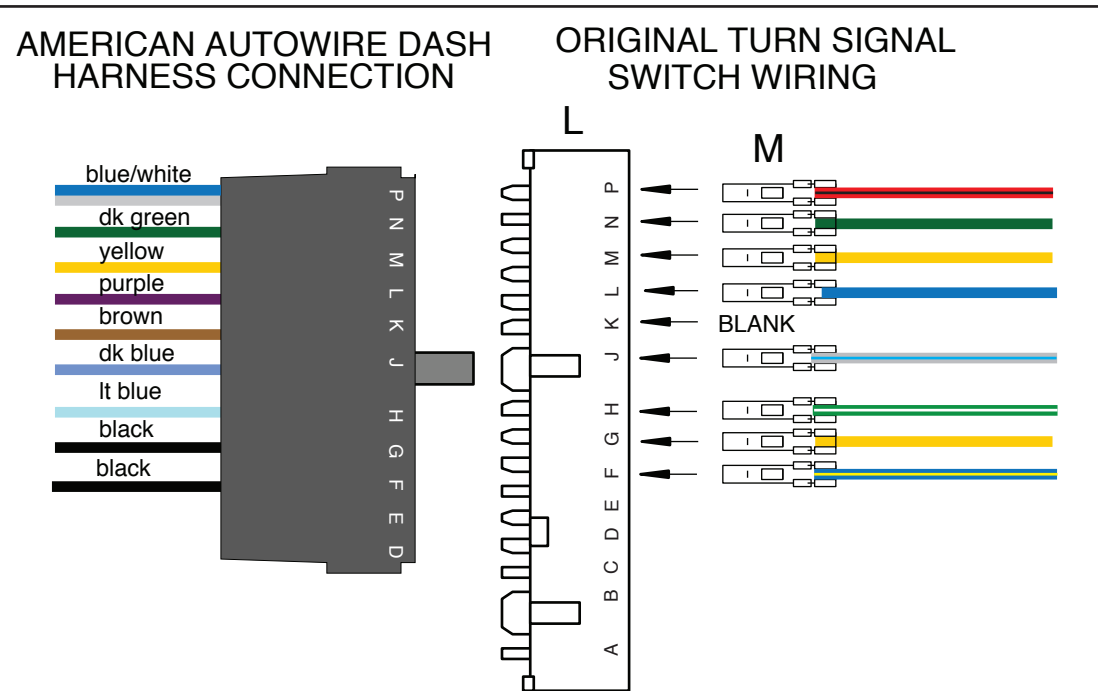

**DIAGRAM 'A' - AAW Turn Signal Switch Wires to Stock 1966-71 Steering Columns.**

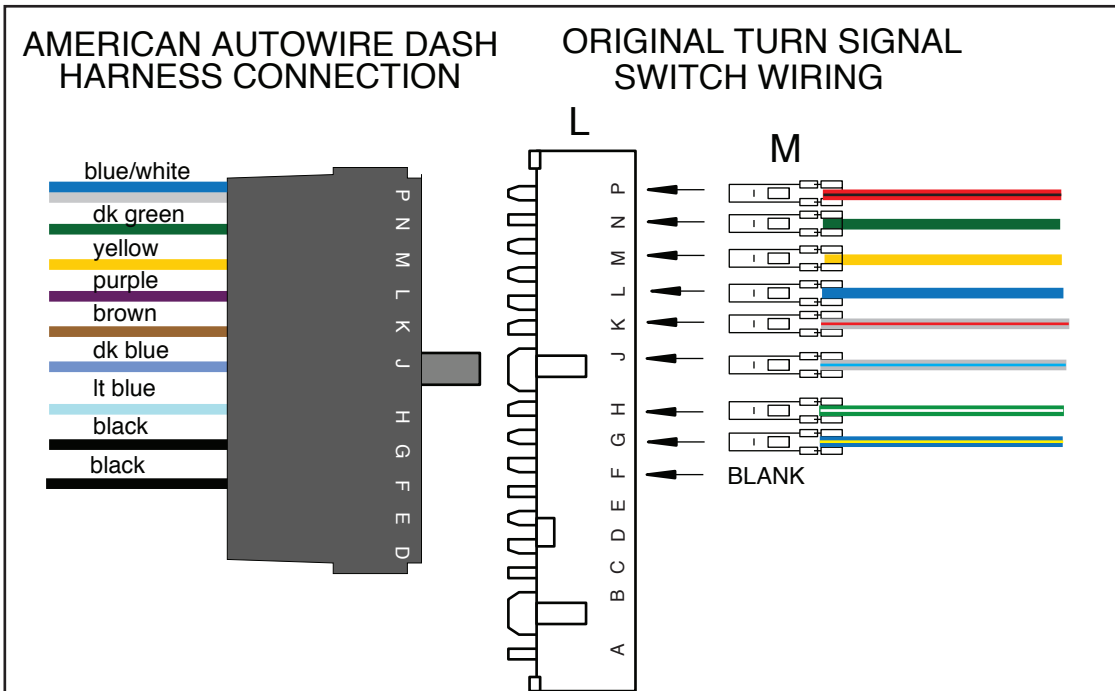

**DIAGRAM 'A' - AAW Turn Signal Switch Wires to Stock 1972-77 Steering Columns.**

### "Table A"

AAW Turn Signal Switch wires to stock **1966-71** Ford Bronco turn signal switch.

AAW Wire #	AAW Wire color	AAW Wire Printing	Ford Wire Color
14A,B	Light Blue	Left Front Turn	Green with white stripe.
15A,B	Dark Blue	Right Front Turn	White with blue stripe.
16B	Purple	Turn Switch Feed	Blue.
17A,B	Blue & White	Brake Switch	Red with black stripe.
18	Yellow	Left Rear Turn	Yellow.
19	Dark Green	Right Rear Turn	Dark Green.
27B	Brown	Turn Sw - Hazard	Not applicable.
28	Black	Horn Relay Ground	Yellow.
28A	Black	Horn Relay Ground	Blue with yellow stripe.

**NOTE:** Ford originally switched 12v power to the horns through the steering column horn button during these years. The AAW kit switches ground through the steering column horn button which grounds a horn relay that switches the power to the horns. Circuit 27B is being provided, if an Emergency Warning Flasher System is to be added.

### "Table A"

AAW Turn Signal Switch wires to stock **1972-77** Ford Bronco turn signal switch.

AAW Wire #	AAW Wire color	AAW Wire Printing	Ford Wire Color
14A,B	Light Blue	Left Front Turn	Green with white stripe.
15A,B	Dark Blue	Right Front Turn	White with blue stripe.
16B	Purple	Turn Switch Feed	Blue.
17A,B	Blue & White	Brake Switch	Red with black stripe.
18	Yellow	Left Rear Turn	Yellow.
19	Dark Green	Right Rear Turn	Dark Green.
27B	Brown	Turn Sw - Hazard	White with red stripe.
28	Black	Horn Relay Ground	Blue with yellow stripe.
28A	Black	Horn Relay Ground	Not applicable.

**NOTE:** The 1972-77 Bronco steering column did not switch power through the column. The steering column horn button switched ground to a horn relay which switches power to the horns just as your new AAW harness does, therefore the 28A wire is not needed, nor will it be used in this application.



**American Autowire**

www.americanautowire.com 856-933-0801

PART # **510317**  
 DESCRIPTION:  
 1966-77 Ford Bronco  
 Classic Update Series Kit

92970069 Rev. 9.0 1/26/2018



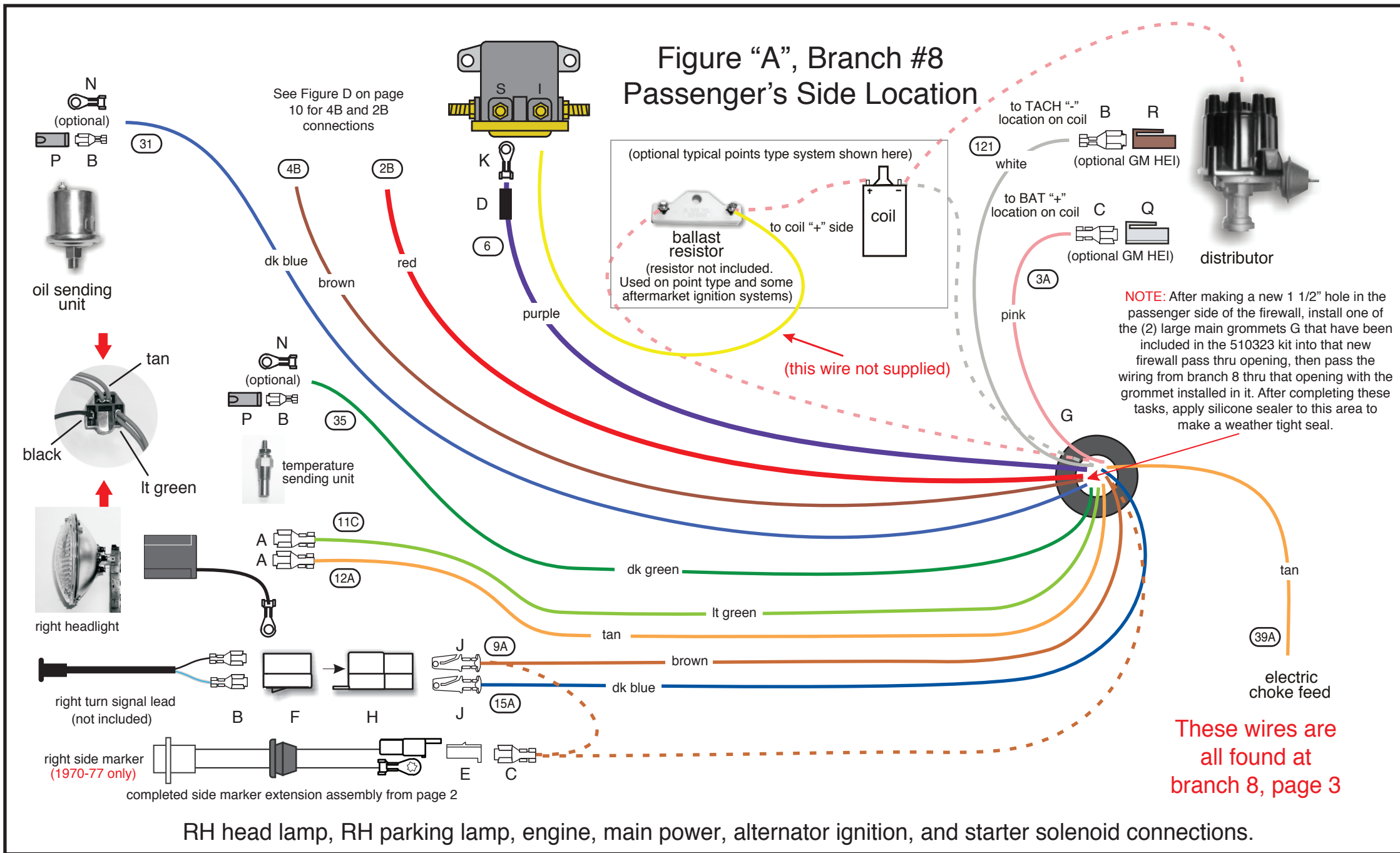

**NOTE:** The terminals and connectors listed on this page and denoted with **UPPER CASE LETTERS** to help you complete the various connections to your lamps, engine connections, switches, etc. can be found in your loose piece clamp, grommet, and parts kit, P/N 510323.

The identifications, colors, and functions for all of the wires listed in "Figures A and B" on this page can be found on page 3, branch 2 and branch 8 of this main instruction set (9270069). AAW suggests and recommends using pages 3 and 9 to complete the installation of the forward lamp, engine, alternator ignition, starter solenoid, and heater connections.

This AAW kit is engineered to work with most aftermarket manufacturer's heating and air conditioning systems. As such, we have provided a keyed 12-volt feed to use as the "OFF / ON" (AAW brown 50 wire) power source for whatever system you choose to purchase. The manufacturer will supply you with a harness for their system and instructions on how to connect it. In the event you are utilizing a stock heater system in your truck, we have also provided wires that will run from your heater switch to your heater resistor and then on to your blower motor. See "Figure B" below for complete installation instructions.

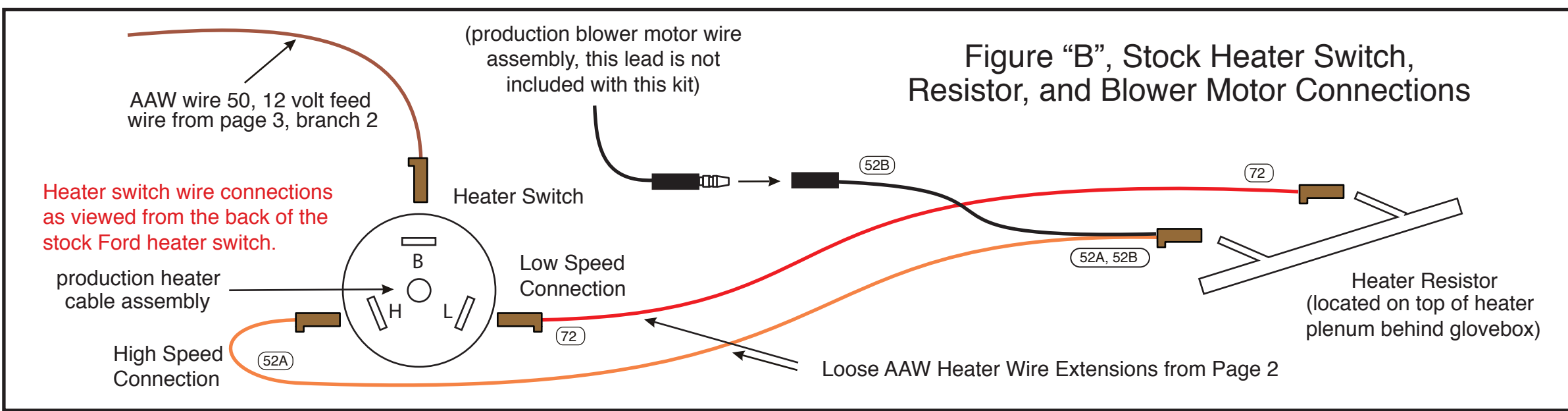

www.americanautowire.com 856-933-0801

PART # **510317**

DESCRIPTION:  
**1966-77 Ford Bronco Classic Update Series Kit**

92970069 Rev. 9.0 1/26/2018

**Figure "C", Branch #7  
Driver's Side Location**

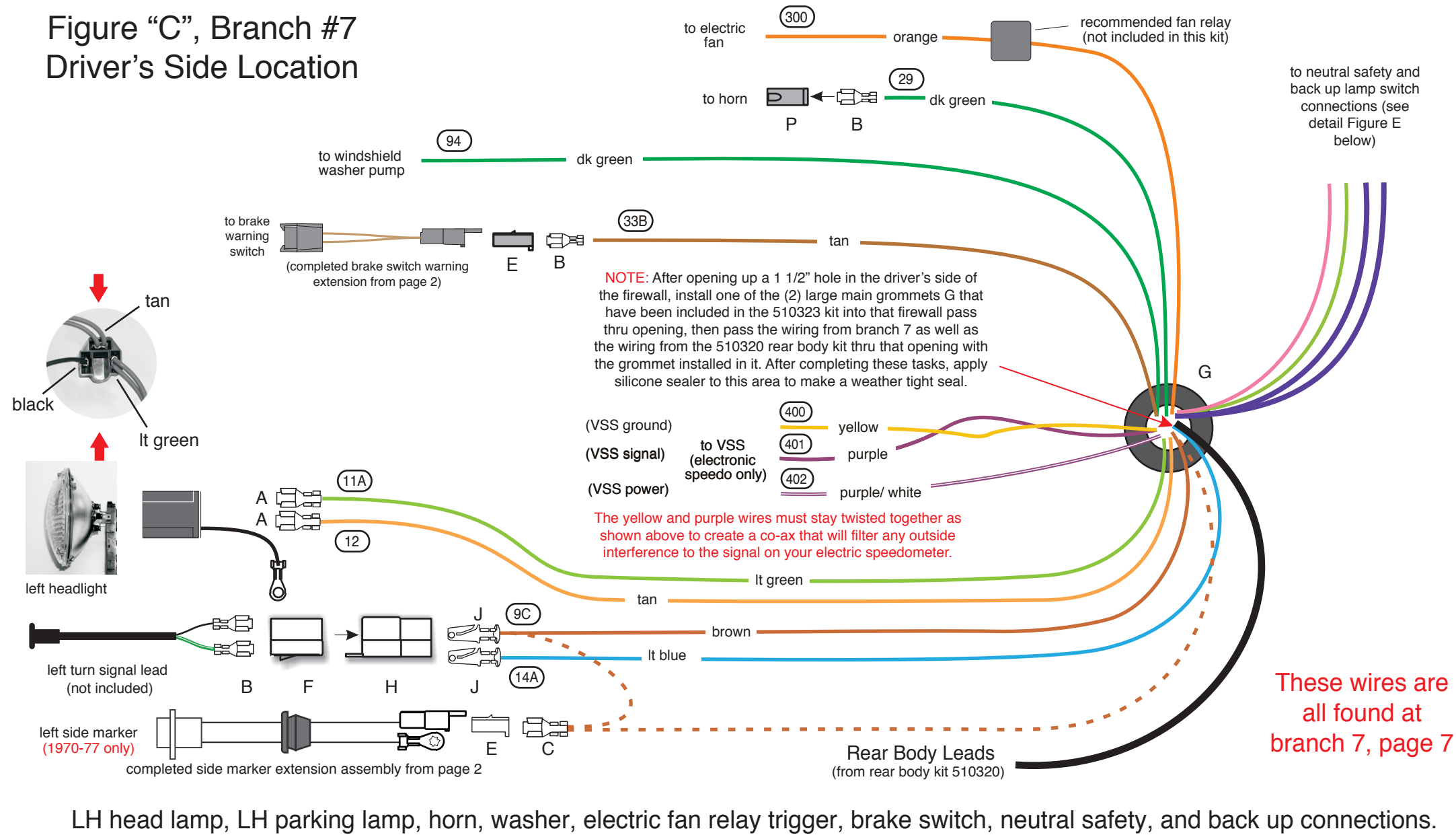

**NOTE:** The terminals and connectors listed on this page and denoted with **UPPER CASE LETTERS** to help you complete the various connections to your lamps, horn, brake warning switch, electric fan, back up and neutral safety switch, washer pump, etc. can be found in your loose piece clamp, grommet, and parts kit, P/N 510323. No terminals have been provided for the neutral safety or back up connections.

The identifications, colors, and functions for all of the wires listed in "Figures C, D, and E" on this page can be found on page 7, branch 7, and page 3, branch 8 of this main instruction set (92970069). AAW suggests and recommends using pages 3, 7, and 10 to complete the installation of the forward lamp, horn, brake warning switch, electric fan, neutral safety and back up switch, washer pump, and alternator power connections.

AAW kits are all engineered to be used in conjunction with a high output, later model internally regulated, or one wire alternator. We do not suggest or support the use of a stock low amperage generator or alternator as they do not supply sufficient current to recharge the battery in a highly modified truck such as this kit was designed for. AAW suggests Ford Gen III (AAW p/n 500802), GM "SI", or 1 wire type alternators as good choices to use. Adapters to complete the connection to these style alternators may be purchased separately if needed. Contact AAW for your needs.

**Figure "D"  
Main Power and  
Alternator Wiring**

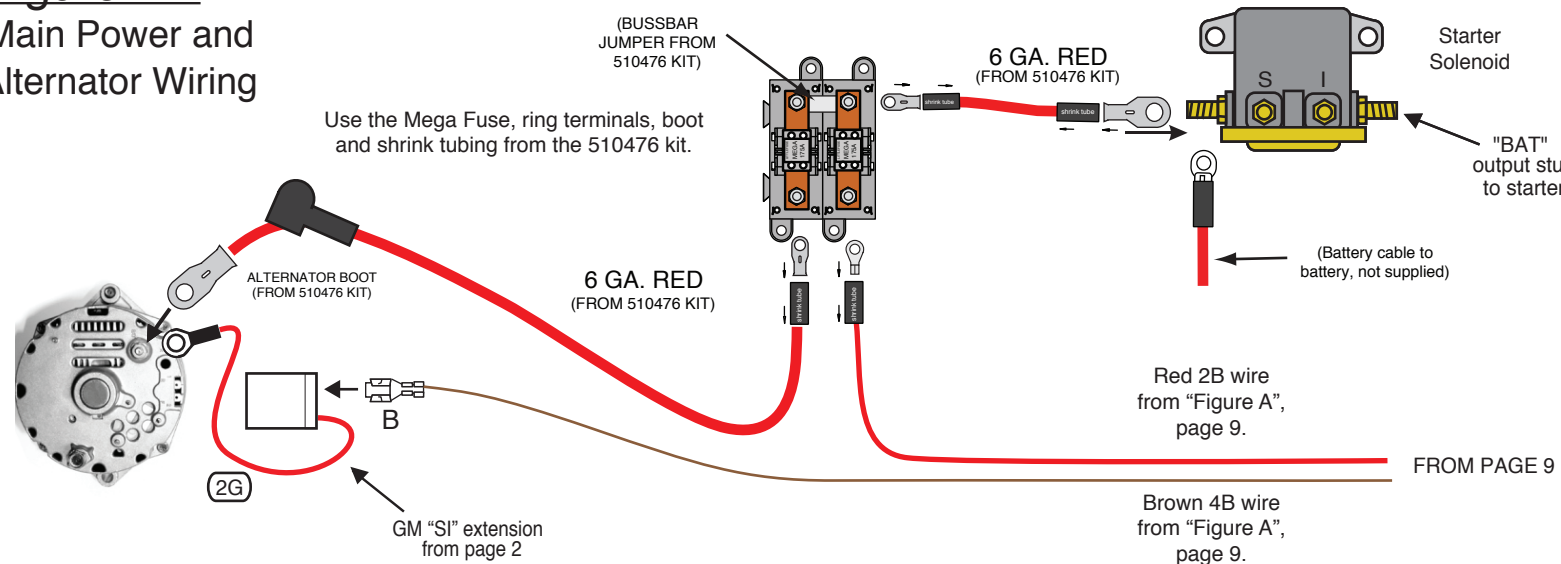

**Figure "E"**

Shown is a typical NSS and Back Up Switch.

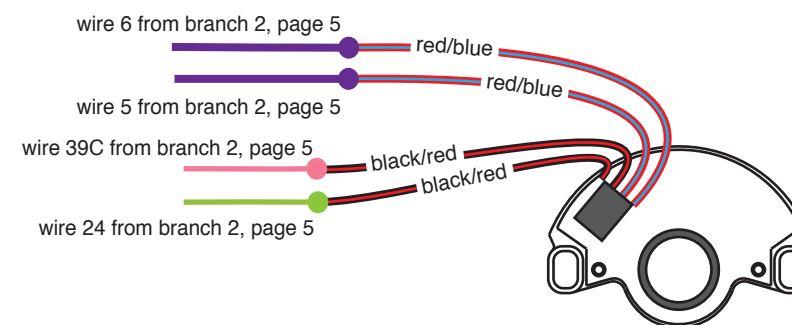

www.americanautowire.com 856-933-0801

PART # **510317**

DESCRIPTION:  
**1966-77 Ford Bronco  
Classic Update Series Kit**

92970069 Rev. 9.0 1/26/2018



## FUSEBOX MOUNTING LOCATION ON THE LH INSIDE OF THE GLOVEBOX

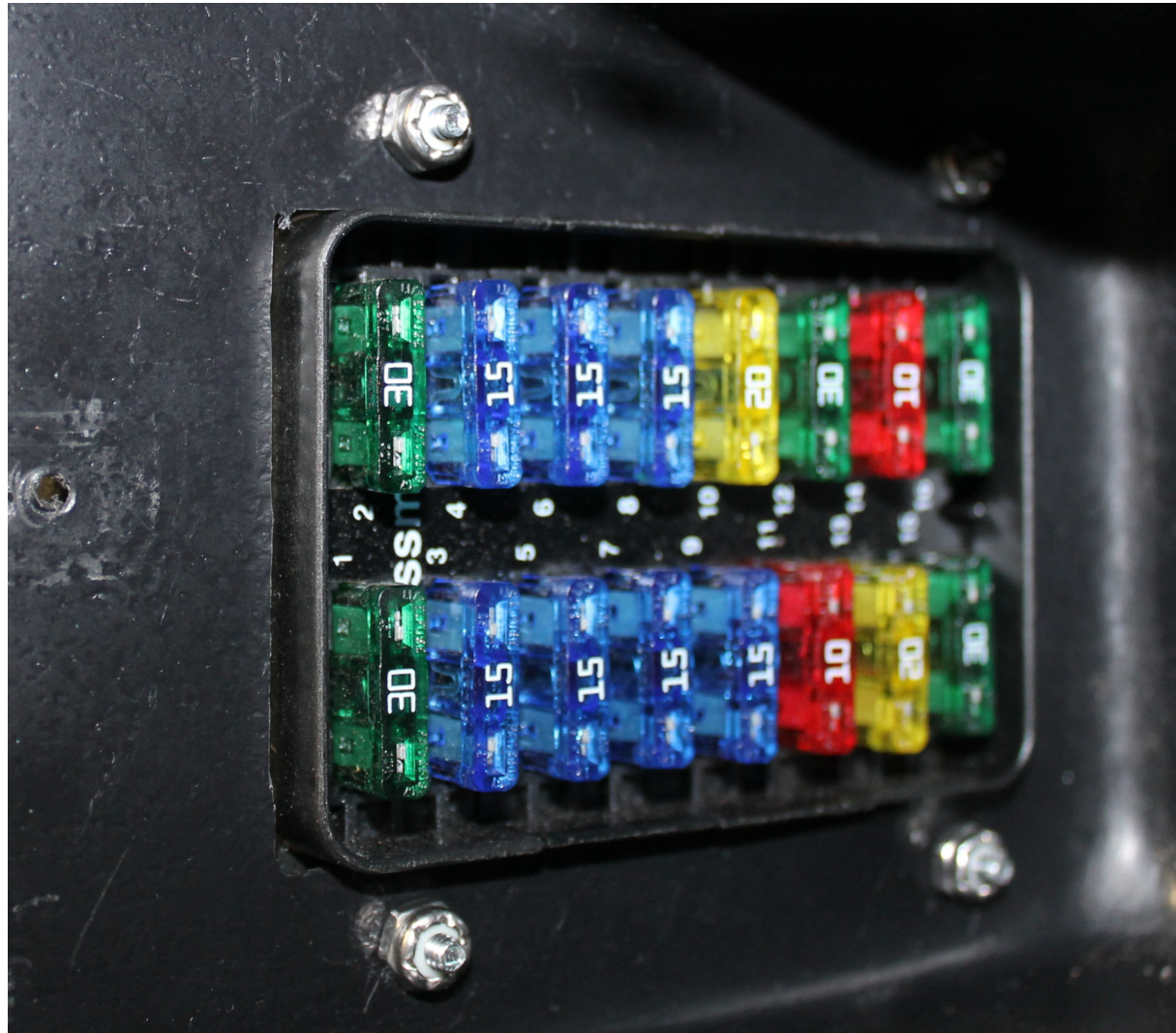

Bat - Spare 30A - BAT	1	2 Pwr Seats 30A - BAT
Park Lights 15A - BAT	3	4 Stop / Crtsy 15A - BAT
Horn 15A - BAT	5	6 Clock - BAT 15A - BAT
Haz / CB 15A - BAT	7	8 Pwr Locks 15A - BAT
Turn 15A - IGN	9	10 Fuel Pump 20A - IGN
Gauges 10A - IGN	11	12 Engine Fan 30A - IGN
Wiper 20A - ACC	13	14 Radio 10A - ACC
Pwr Window 30A - ACC	15	16 Heat / AC 30A - ACC

Fuse label on inside of Fuse Box lid

NOTE: On this page, you will find a photograph of the completed fusebox and dash harness assembly as it would install in your vehicle. This harness cannot be used with the stock dash speaker as the new AAW fuse panel installs in the same location as the stock radio speaker does. You will need to purchase a new plastic glovebox liner assembly that does not have a stock fusebox hole in it to mount the new AAW harness into your vehicle. A template (92970085) to modify the new glove box assembly has been included with this kit. We have provided 4 attaching nuts for you to affix the fusebox to the inside of the glove box. They can be found in the 510318 loose piece dash kit. With the new fuse panel assembly mounted inside the glovebox liner, the main bundle or trunk of the new AAW dash harness assembly should be heading toward the firewall away from the front of the dashboard assembly.



www.americanautowire.com 856-933-0801

PART # **510317**  
DESCRIPTION:  
1966-77 Ford Bronco  
Classic Update Series Kit

92970069 Rev. 9.0 1/26/2018

This page intentionally left blank.



[www.americanautowire.com](http://www.americanautowire.com) 856-933-0801

PART # **510317**  
DESCRIPTION:  
1966-77 Ford Bronco  
Classic Update Series Kit

92970069 Rev. 9.0 1/26/2018

\*\*\* These are special instructions for connecting your wiring system to a stock instrument cluster. \*\*\*

**Note:** If you are using aftermarket gauges, follow the instructions included in the 92965220 Gauge Connection Kit along with the specific gauge manufacturers instructions for connection of their gauges.

If you are using the stock gauges and warning lamps, refer to the diagrams on the following pages for your application. Use the enclosed parts and information below for wire termination, gauge, and lamp connections. Connectors A, B, and C will plug into your dash harness at branch 5 as noted on the Dash Harness instruction (92970069, bag G) sheet. Connection C will only be used in the event that you are using an electric speedometer.

## CONNECTOR A (sheet 2)

BROWN	Accessory Feed	This wire is used to connect 12v switched power to the factory constant voltage unit. After installing the feed wire onto the constant voltage unit, use the remaining wire to connect from the constant voltage unit to the factory fuel, oil, and temperature gauge unit power studs where your original black w/ green stripe wire attached.
PINK	12v ignition	If your truck is equipped with aftermarket gauges, plug this loose wire into Connector A maintaining color continuity with the mating connector on your dash harness, install components shown on sheet 2, and connect to the proper aftermarket gauges.
GREY	Instrument Lamps	Install components shown on sheet 2, and plug into the instrument lamp holes in the cluster.
BLACK	Ground	Install components shown on sheet 2, and connect to the back of the instrument cluster housing.

## CONNECTOR B (sheet 3)

DK BLUE	Right Turn Indicator	Install components shown on sheet 3, and plug into the right turn hole in the cluster.
LT BLUE	Left Turn Indicator	Install components shown on sheet 3, and plug into the left turn hole in the cluster.
LT GREEN	Hi Beam Indicator Lamp	Install components shown on sheet 3, and plug into the high beam indicator hole in the cluster.
DK BLUE	Oil Gauge	Install components shown on sheet 3, and attach onto the oil gauge sender stud where your original white w/ red stripe wire attached.
DK GREEN	Temp Gauge	Install components shown on sheet 3, and attach onto the temperature gauge sender stud where your original red w/ white stripe wire attached.
TAN	Fuel Gauge	Install components shown on sheet 3, and attach onto the fuel gauge sender stud where your original orange wire attached.
WHITE	Tach (loose wire)	If your truck is equipped with an aftermarket tach, plug this loose wire into Connector B maintaining color continuity with the mating connector on your dash harness, install components shown on sheet 3, and plug onto the tachometer.

## CONNECTOR C (sheet 4)

This connector is used when using an aftermarket electronic speedometer only. Follow the manufacturer's instructions when installing these wires. If you are using the stock speedometer, then discard this connector. See page 4 for wire descriptions and typical connections.



**American  
Autowire**

www.americanautowire.com 856-933-0801



# Classic Update Series

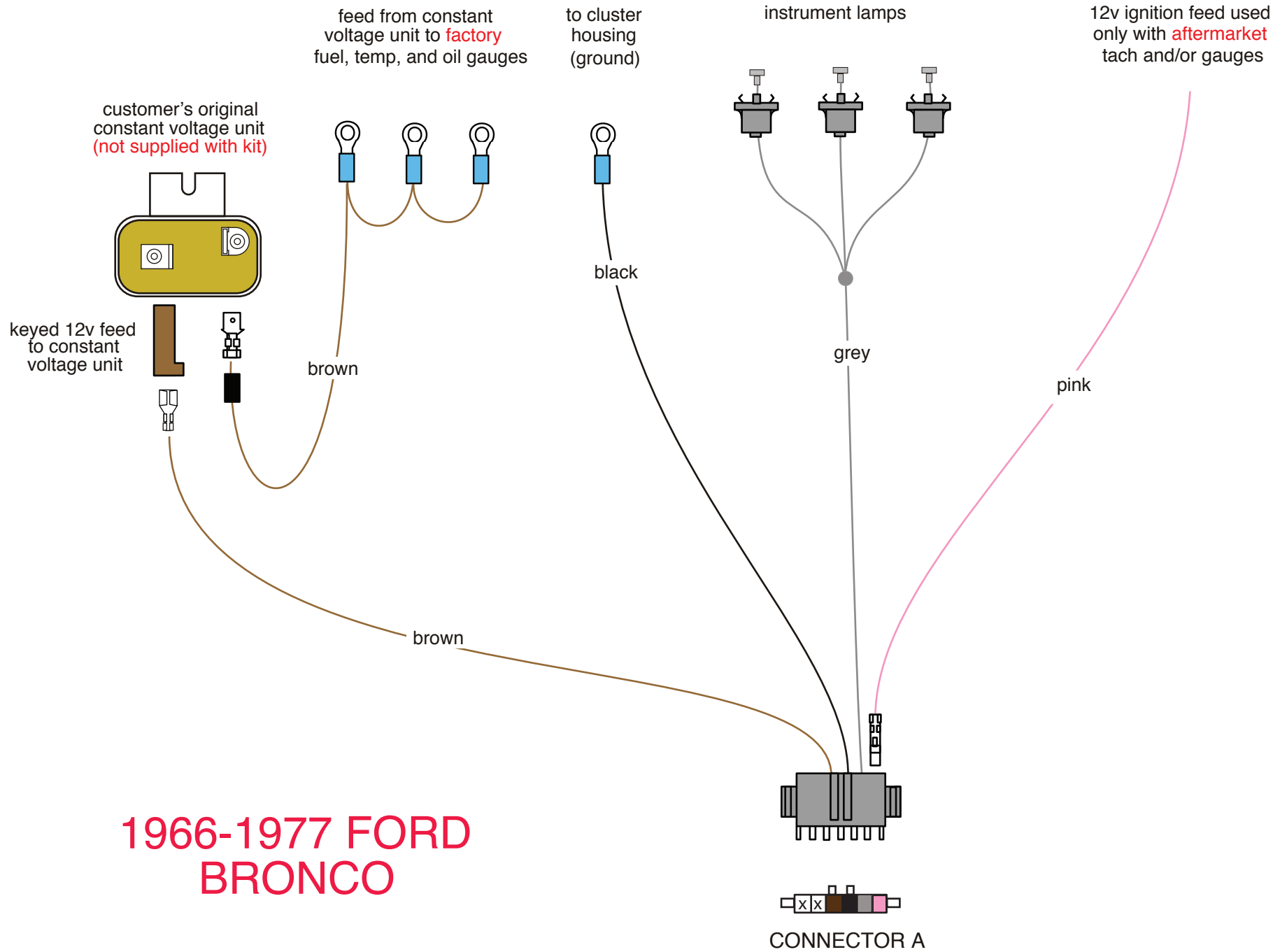

## 1966-1977 FORD BRONCO

# Classic Update Series

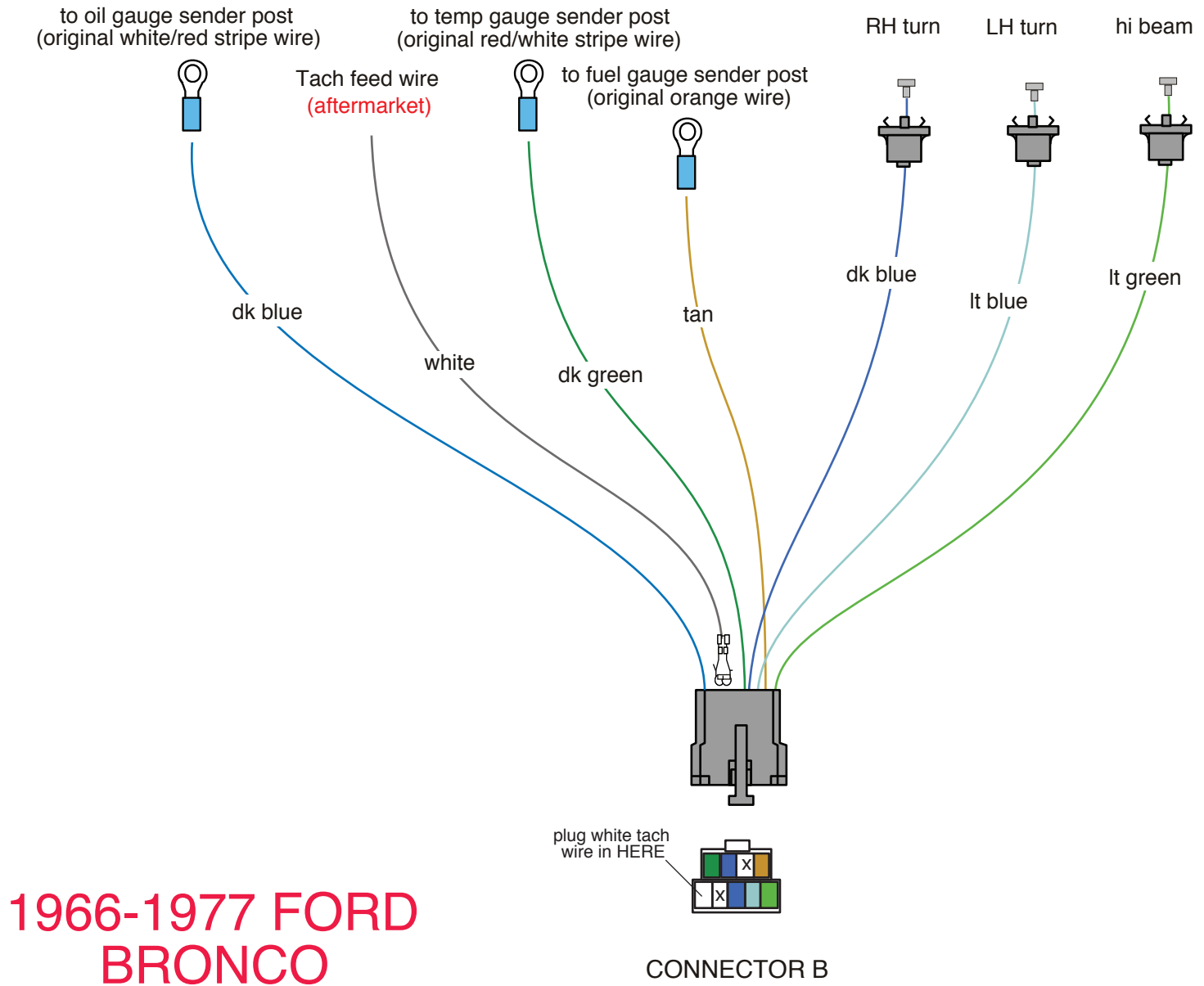

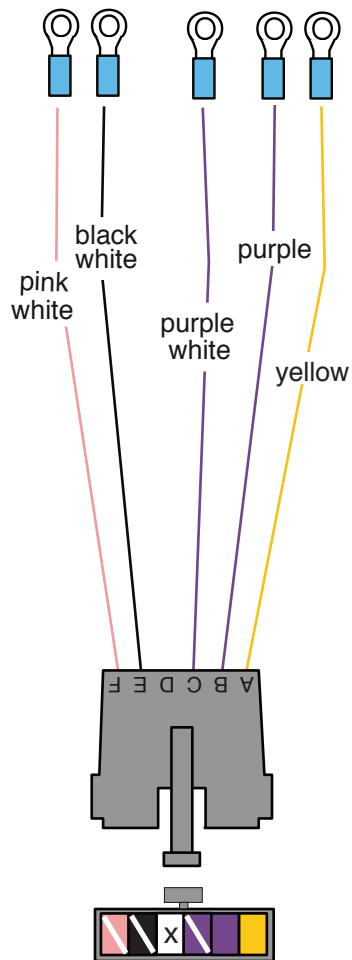

CONNECTOR C

## TYPICAL ELECTRIC SPEEDO CONNECTIONS

Below are some general instructions for hooking up an electric speedometer. This connector and these instructions will ONLY be used in the event that you are utilizing an aftermarket electric speedometer. If your car does NOT have an electric speedometer, this connection will NOT be used and should not be plugged onto your dash harness. It is best to consult the speedometer manufacturer's instructions if you have any questions.

<u>Yellow</u>	VSS Ground	Connect to VSS "-" on speedometer.
<u>Purple</u>	VSS Signal	Connect to VSS input on speedometer.
<u>Purple/White</u>	VSS Power	Connect to 12V power on speedometer.
<u>Black/White</u>	Speedo Ground	Connect to ground on speedometer.
<u>Pink/White</u>	Speedo Power	Connect to 12v power on speedometer. <u>NOTE:</u> This wire will double onto the same stud as the purple/white VSS power wire from above.



# Classic Update Series

 orange

("12 volt battery fused" - only used with LED tail lamps)  
Plug into the main connector and maintain continuity with dash harness.

 lt blue

("Third brake light" - only used when needed)  
Plug into the main connector and maintain color and function continuity with dash harness. See below for suggested connection.

 white

("Gas gauge aux tank." - only used when needed)  
Plug into the main connector and maintain color and function continuity with dash harness. See below for suggested connection.

 lt blue

("12V CTSY SW" - dome lamp feed. Only used when needed)  
Plug into the main connector and maintain color and function continuity with dash harness. See below for suggested connection.

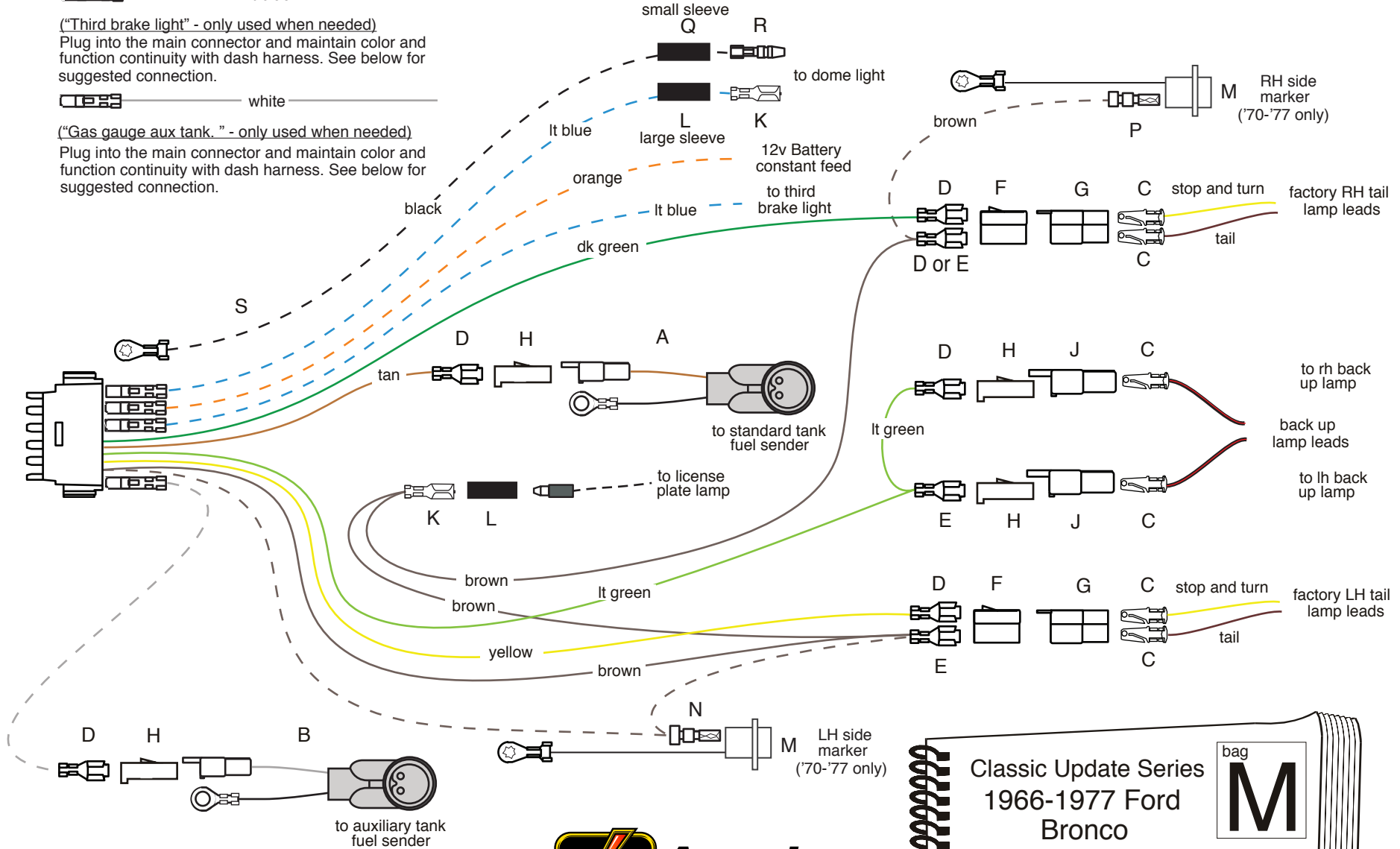

1966-1977 Ford Bronco



**American  
Autowire**

www.americanautowire.com 856-933-0801

Classic Update Series  
1966-1977 Ford  
Bronco

bag  
**M**

REAR BODY KIT

**510320**

92970080 instruction rev 0.0 5/25/2012

## 1966-1977 Ford Bronco

**NOTE:** We have provided you with 2 new factory reproduction rear body inner panel pass through grommets which are located in the loose piece kit contained inside this rear body harness kit (510320). We suggest that before you install any of the new wiring from this rear body kit, that you remove the old grommets from the inner rear tail lamp area of your truck and replace them with the new ones included in this kit to ensure that the wires do not get chaffed when passing them through the inner LH and RH openings inside of the body.

Connect this main connector to the mating connector on the dash harness 510318, bag G. Route the tail lamp, back up lamp, and fuel tank wires out through the LH grommet and hole in the firewall, down the firewall, and to the back of the truck along the inner side of the driver's frame rail.

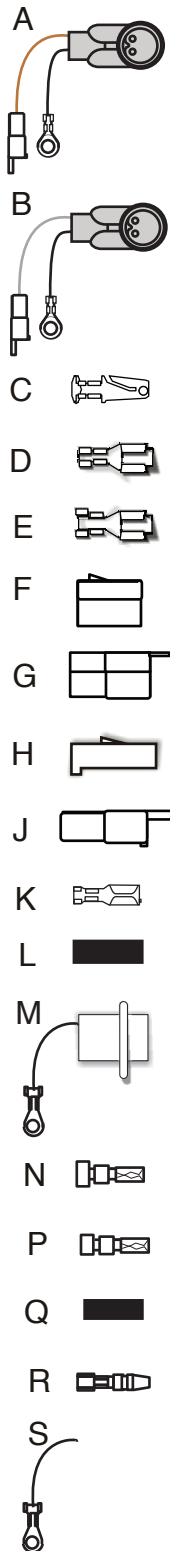

**LIGHT BLUE** Third Brake Light Plug this loose wire into the main connector maintaining color and function continuity with the dash harness (510318), then connect the other end to the third brake lamp if so equipped.

**NOTE:** You have been provided with molded fuel tank sending unit extensions for both the main (item A) and auxiliary (item B) fuel tanks which are fully terminated and are ready for installation. Once you have completed the routing and termination of the tan and white (if you have a second tank) fuel tank wires below, plug these extensions A and B onto the tan and white wires per the instructions to complete your fuel tank sender circuits.

**TAN** Gas Gauge Route this wire to the main fuel tank sending unit, cut to length, install terminal D, plug into connector H as shown on sheet 1, and plug into the tan fuel tank sender extension A from above. Install the completed tan fuel tank sender extension A onto the sender of the main tank and then ground the ring terminal on the black wire of the tan fuel tank extension A to the frame to complete the main fuel tank sender connection.

**WHITE** Gas Gauge Aux Tank If your truck has an auxiliary fuel tank, plug this loose wire into the main connector maintaining color and function continuity with the dash harness (510318), route the wire to the auxiliary fuel tank sending unit, cut to length, install terminal D, plug into connector H as shown on sheet 1, and plug into the white fuel tank sender extension B from above. Install the completed white fuel tank sender extension B onto the sender of the auxiliary tank and then ground the ring terminal on the black wire of the white fuel tank extension B to the frame to complete the auxiliary fuel tank sender connection.

**NOTE:** There are 2 different ways to connect the brown wires. The 1966-69 Broncos did not use side marker lamps, whereas the 1970-77 Broncos did use side marker lamps. We have provided 2 side marker lamp pigtails M with ground wire and ring terminal fully terminated that are ready for installation. Please take note of your application and connect the brown wires accordingly.

**BROWN** Running Lamps **(1966-69 Bronco without side marker lamps)** Route this wire to the LH tail lamp area, cut to length, double this wire with the cut off portion, install terminal E and plug into connector F in the location shown on sheet 1. Route the loose end of this brown wire to the license lamp area, cut to length, double this wire with the cut off portion, install terminal K and slide rubber sleeve L back over terminal K as shown on sheet 1. Route the loose end of this brown wire to the RH tail lamp area, cut to length, install terminal D and plug into connector F in the location shown on sheet 1.

**(1970-77 Bronco with side marker lamps)** Route this wire to the LH side marker lamp area, cut to length, double this wire with the cut off portion, install terminal N and plug into into the empty cavity of one of the side marker pigtails M shown on sheet 1. Route the loose end of this wire to the LH tail lamp area, cut to length, double this wire with the cut off portion, install terminal E and plug into connector F in the location shown on sheet 1. Route the loose end of this brown wire to the license lamp area, cut to length, double this wire with the cut off portion, install terminal K and slide rubber sleeve L back over terminal K as shown on sheet 1. Route the loose end of this brown wire to the RH tail lamp area, cut to length, install terminal E and plug into connector F in the location shown on sheet 1. Route the loose end of this brown wire to the RH side marker lamp area, cut to length, install terminal P and plug into into the empty cavity of the other side marker pigtail M shown on sheet 1.

# Classic Update Series

## 1966-1977 Ford Bronco

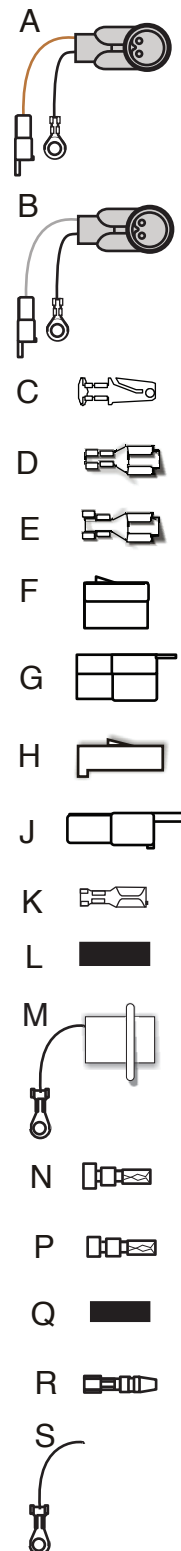

YELLOW	LH Stop / Tail
DK GREEN	RH Stop / Tail
LIGHT GREEN	Back Up Lamp Feed
LIGHT BLUE	12V Courtesy Switched
BLACK	Ground
ORANGE	12 Volt Battery Fused

Route this wire to the LH tail lamp area, cut to length, install terminal D and plug into the empty cavity of connector F as shown on sheet 1. Terminals C and connector G have been provided for you to crimp onto your stop and tail lamp leads to complete the connection to the LH stop, turn, and tail assembly.

Route this wire to the RH tail lamp area, cut to length, install terminal D and plug into the empty cavity of connector F as shown on sheet 1. Terminals C and connector G have been provided for you to crimp onto your stop and tail lamp leads to complete the connection to the RH stop, turn, and tail assembly.

Route this wire to the LH back up lamp area, cut to length, double this wire with the cut off portion, install terminal E, and plug into connector H as shown on sheet 1. Route the loose end of this light green wire over to the RH back up lamp area, cut to length, install terminal D, and plug into connector H as shown on sheet 1. Terminals C and connectors J have been provided for you crimp onto your back up lamp leads to complete the connection to the LH and RH assemblies.

**NOTE:** The 66 through 74 Broncos had a dome lamp that was grounded through the dome lamp housing which did not require a separate ground wire. The 75 through 77 Broncos did require a separate ground wire. We have provided you with a switched 12v feed wire (light blue) which will be used in either application. We have also provided a separate black ground wire for use with the 74 through 77 Broncos only. Please follow the dome lamp connections that apply to your application as outlined below and in the drawing on sheet 1.

**(These directions apply to both the 66-74 and 75-77 applications).** If your truck utilizes a dome lamp assembly, plug this loose wire into the main connector maintaining color and function continuity with the dash harness (510318), then route this wire up through the windshield frame to the dome lamp unit. If you are using the aftermarket unit that mounts in the back of the truck, you will have to route this wire to the back of the truck as well. Cut the wire to length, slide the larger rubber sleeve L onto the wire, crimp terminal K onto the wire and slide the rubber sleeve back over the terminal to protect the terminal from shorting out against any sheet metal. Install the completed wire assembly onto the dome lamp unit. If your truck is a 66-74 model, your dome lamp circuit is now completed. (This is your dome lamp 12 volt feed wire). If your truck is a 75-77 model, continue onto the next step with the black ground wire.

**(These directions apply to 75-77 applications only, as the 66-74 dome lamp assembly typically has a ground wire attached to it, or is self grounding, so this wire is not used in those applications).** If your truck utilizes a dome lamp assembly, route the loose end of wire S up through the windshield frame to the dome lamp unit. If you are using the aftermarket unit that mounts in the back of the truck, you will have to route this wire to the back of the truck as well. Cut the wire to length, slide the smaller rubber sleeve Q onto the wire, then crimp terminal R onto the wire. Slide the rubber sleeve up to the bottom of the terminal so that the bullet end is left exposed. Install this end of your completed wire assembly onto the dome lamp unit assembly pigtail. Attach the other end of this wire (with the ring terminal on it) that comes out the bottom of the windshield frame to a known good chassis ground to complete your dome lamp circuit.

If your truck has LED tail lamps that require a full time 12 volt battery feed for memory purposes, plug this loose wire into the main connector maintaining color and function continuity with the dash harness (510318), route this wire to the LH stop, turn, and tail assembly, attach it to the LH lamp assembly per the manufacturer's instructions, then continue the orange wire on over to the RH stop, turn, and tail assembly and attach it to the RH lamp assembly per the manufacturer's instructions.



This page has been intentionally left blank.

## In this kit you will find the following:

1. 2 Main firewall grommets.
2. Misc. connectors and terminals to complete engine, alternator, and forward lamp connections.

Some early Broncos had rectangular holes in the firewall behind the engine and a small round hole in the upper driver's side of the firewall. If your Bronco is configured this way, you will need to open up that driver's side hole to 1 1/2" and you will need to make a new 1 1/2" hole on the passenger's side as well before installing your new AAW Bronco Classic Update wiring harness. The later Broncos actually used this 1 1/2" hole on either side of the firewall configuration. The center rectangular hole will not be used at all and should be closed up in some way. The 2 new main firewall grommets listed above will be used to line the two new or existing 1 1/2" holes. Your LH and RH under hood branches of your dash/main harness (510318) will exit the cab of the truck through these 2 grommets out into the engine bay. The various terminals and connectors that are included in this bag will be used to complete the many connections under the hood of your Bronco. These detailed installation instructions of how to route the harness and what connectors to install on which wires can be found on pages 9 and 10 of the main instruction set (92970069).

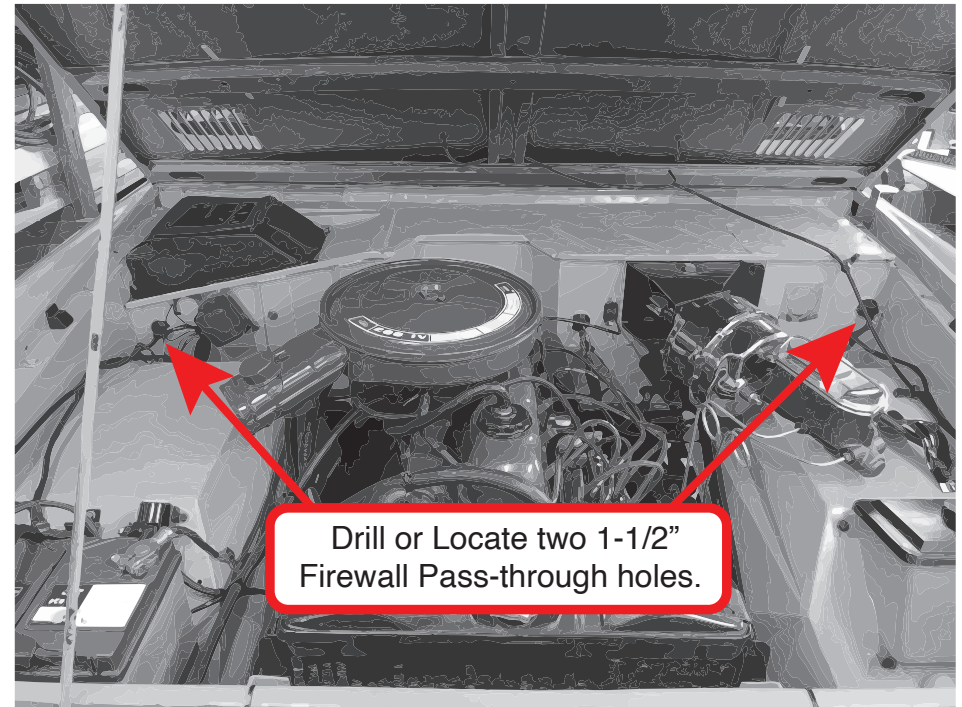

**American  
Autowire**

www.americanautowire.com 856-933-0801

PART #

**510323**

DESCRIPTION:

Clamp, Grommet, and Parts Kit  
1966-77 Ford Bronco  
Classic Update Series

92970089 Rev 3.0 11/20/2023

**In the box below, you will find the legend for the misc. terminals, plastic connector bodies, and the main firewall grommets that will be used to complete your main power, forward lighting, engine, and alternator connections. They are itemized and referred to on this page just as they are on pages 9 and 10 of the Main instruction set (92970069).**

**A**  (larger 59 series single female terminal, 6 pcs.)

**B**  (smaller 56 series single female terminal, 15 pcs.)

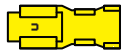
**C**  (smaller 56 series double female terminal, 6 pcs.)

**D**  (large rubber sleeve, 6 pcs.)

**E**  (56 series single female conn. with lock wedge, 4 pcs.)

**F**  ("T" shaped 56 series double female connector, 2 pcs.)

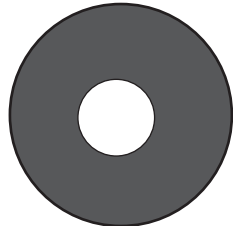
**G**  (2 large main firewall grommets, 2 pcs.)

**H**  ("T" shaped 56 series double male connector, 2 pcs.)

**J**  (56 series single male terminal, 6 pcs.)

**K**  (small ring terminal for larger gauge wire, 6 pcs.)

**M**  (small rubber sleeve, 2 pcs.)

**N**  (small ring terminal for smaller gauge wire, 2 pcs.)

**P**  (56 series single female conn. with notch, 2 pcs.)

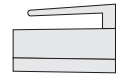
**Q**  (56 series single female HEI power conn., 1 pc.)

**R**  (56 series single female HEI tach conn., 1 pc.)



A  (1)  
 (144.0" 6 Gauge charge wire)

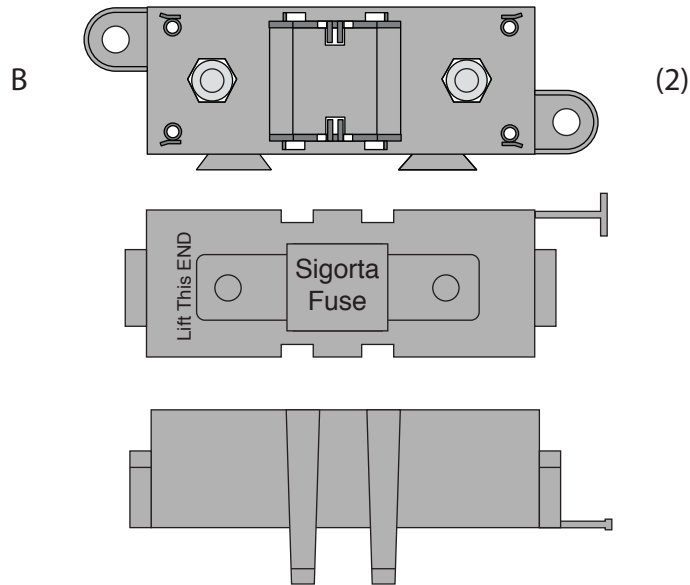

1. On this page, you will find the wire, fuse bodies, fuses, boot, ring terminals, and shrink tubing (items A through K) that are necessary to connect your alternator and main power feed for your new AAW wiring kit. Please be sure that all of the necessary components are present before starting this portion of your installation. If anything is missing, stop what you are doing and contact AAW at the number listed below right away.

2. On page 2, you will find directions for building the 2 Megafuse assemblies (items B,C and D) into one unit.

3. On page 3, you will find an overall concept of how to connect the Megafuse assemblies to your starter solenoid, alternator and main power feed of your new wiring system.

4. On page 4, you will find tips on building your charging circuit wires and assembling them and the main panel power feed wire to the Megafuse assemblies.

(Megafuse body, cover and two M8 x 1.25 nuts / lock washers)

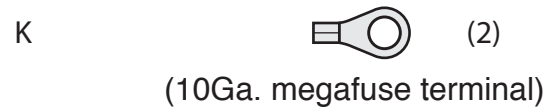
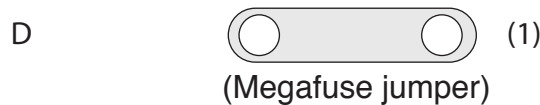
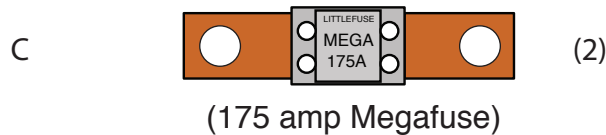

www.americanautowire.com 856-933-0801

PART #

510476

Z

DESCRIPTION:

Alternator and Main Power  
 Connection Kit  
 Various Applications

92972153 instruction sheet rev 0.1 6/24/2019

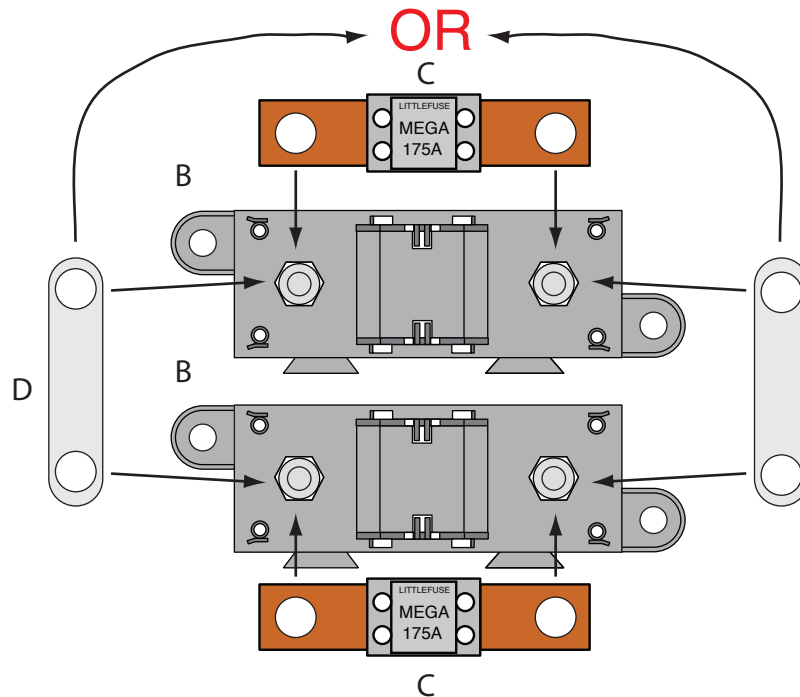

## Assembling the (2) Megafuse assemblies

**NOTE:** Find a suitable place, as close to the battery power source as possible, under the hood of your vehicle to mount the completed Megafuse assemblies. Keep in mind that you have 12 feet of 6Ga. charging wire, and that the main power feed coming from your panel or bulkhead connection must also be able to reach the assembly.

1. Take the two Megafuse bodies and covers (items B) and snap them together. Remove the 4 nuts and lock washers from the studs on the fuse body assemblies.
2. Install the Megafuse jumper (item D above) over two of the studs on the Megafuse bodies. It is very important that the jumper **MUST BE** assembled on the side that is going to connect to your main power connection (starter solenoid or battery feed).
3. Notch top cover to clear jumper D as shown at right.
4. Snap one 175amp fuse (items C) onto the studs of each of the two Megafuse bodies (items B), over the jumper, then loosely re-attach the 4 nuts and lock washers back onto the assembled Megafuses. The fuse assemblies are ready to install into your vehicle.

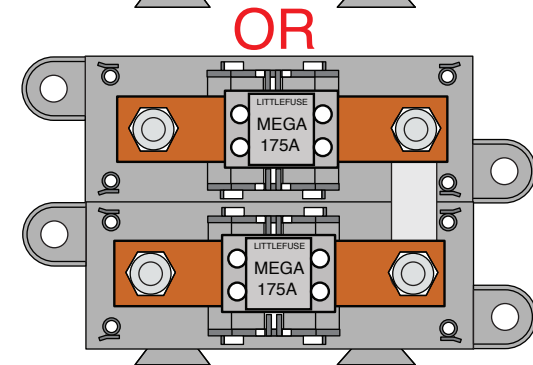
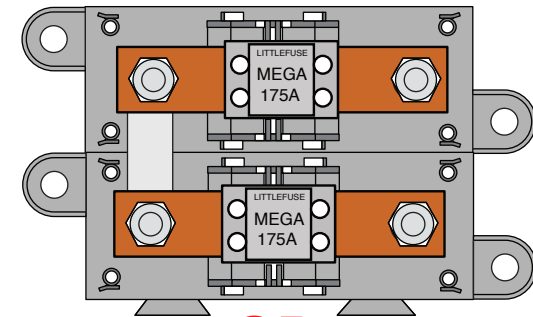

## Assembled Megafuses

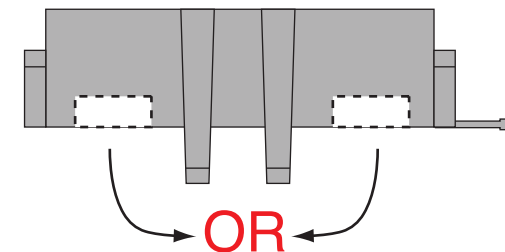

## Notched Cover

PART #

**510476**

**Z**

DESCRIPTION:

Alternator and Main Power  
Connection Kit  
Various Applications

92972153 instruction sheet rev 0.1 6/24/2019



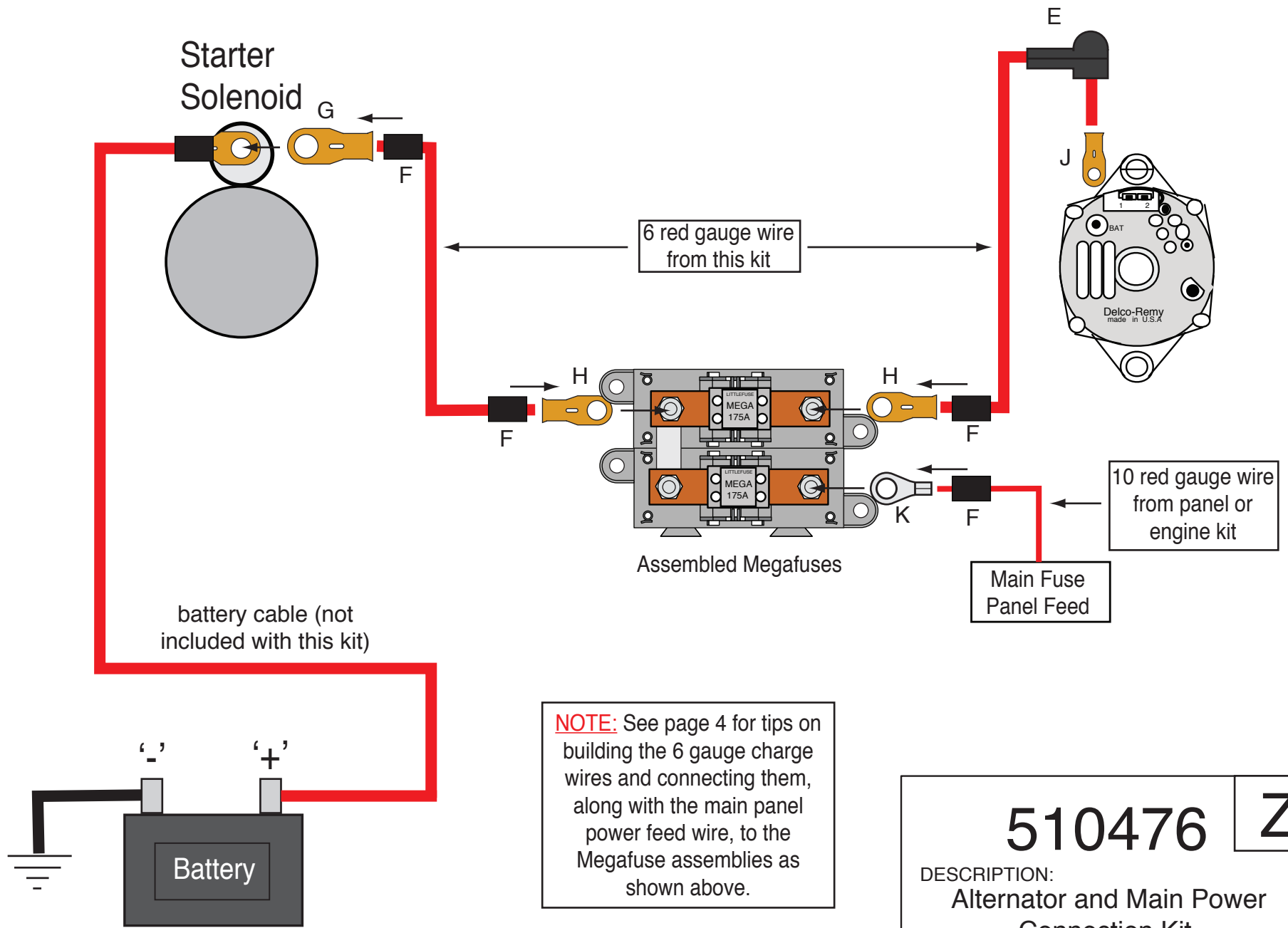

**NOTE:** See page 4 for tips on building the 6 gauge charge wires and connecting them, along with the main panel power feed wire, to the Megafuse assemblies as shown above.

<h1>510476</h1>	<b>Z</b>
<p>DESCRIPTION:  <b>Alternator and Main Power Connection Kit</b>  <b>Various Applications</b></p>	
<p>92972153 instruction sheet rev 0.1 6/24/2019</p>	

## **Building the 6Ga. charge wires and connecting them and the main panel power feed wire to the Megafuse assemblies:**

**NOTE:** Make sure that your battery is disconnected! You will need to install the preassembled Megafuses from page 2 in your vehicle to start this part of the installation.

1. Pre-cut item F shrink tubing into (6) 1.00" - 1.25" pieces.
2. Take the 12-foot piece of 6Ga. red wire from this kit and route it from your starter (or other battery feed) over to the area where you have mounted your Megafuse and cut it to length. Strip the insulation on each end back 1/2". Install 2 pieces of shrink tubing F onto the wire. At the starter end, crimp and solder (1) of terminal G onto the wire. At the Megafuse end, crimp and solder (1) of terminal H onto the wire. Slide the shrink tubing over the terminals and heat it up to shrink it down.
3. Take the remaining portion of the 12-foot piece of 6Ga. red wire from this kit and route it from your alternator over to the area where you have mounted your Megafuse and cut it to length. Strip the insulation on each end back 1/2". Install 1 piece of shrink tubing F onto the wire. At the alternator end, slip on boot E as shown on page 3, then crimp and solder (1) of terminal J onto the wire. At the Megafuse end, crimp and solder (1) of terminal H onto the wire. Slide the shrink tubing over terminal H and heat it up to shrink it down.
4. Take the 10Ga. red main power feed wire from your engine or panel sub-kit and route it over to the area where you have mounted your Megafuse and cut it to length. Strip the insulation back 3/8". Install 1 piece of shrink tubing F onto the wire, then crimp and solder (1) of terminal K onto the wire.
5. Remove the 4 loosely tightened nuts and lock washers from the assembled Megafuses, then using the drawing on page 3 as a guide, install your pre-assembled wires from steps 2-4 above. Re-install the 4 nuts and lock washers onto the assembled Megafuses and tighten them down. This part of your installation is now complete.

**510476**

**Z**

DESCRIPTION:

**Alternator and Main Power  
Connection Kit  
Various Applications**

92972153 instruction sheet rev 0.1 6/24/2019

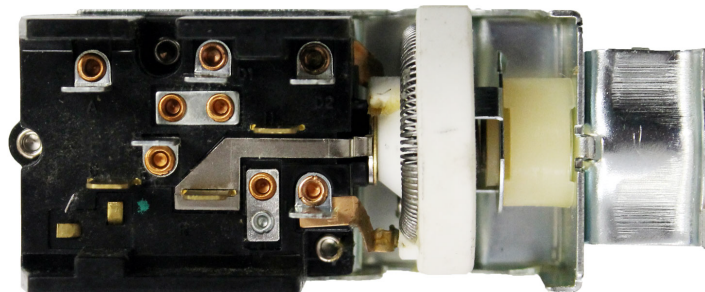
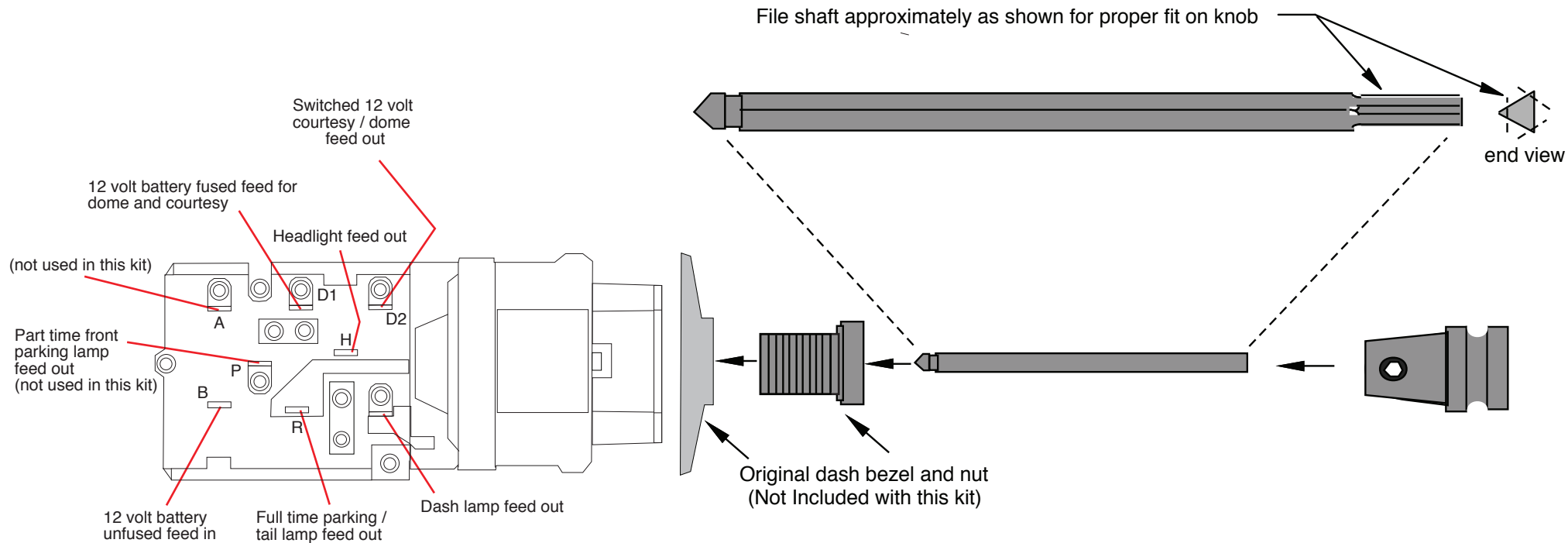

1. Install the new switch into your dash using the original bezel and nut. It will be necessary too cut the shaft for a nice custom installation.
2. Install the shaft in switch being certain that it is fully engaged inside the switch. Once the shaft is fully seated down inside the switch in the "off" position, place the knob on end of shaft. Measure how far away from the dash the bottom face of the knob (closest to dash) is. Allow for 1/4" or so extra so that the knob will not bottom out on dash once the shaft has been cut to length.
3. Remove the shaft from the switch. To do this, pull the shaft completely out to the "on" position. Reach up under the dash and depress the button on top of the switch and pull the shaft out of the switch. Cut the shaft based on your measurements. It may be necessary to file the end of the shaft once it has been cut in order to reinstall the knob onto the shaft.
4. Attach the knob to the cut shaft and tighten the allen screw.
5. Reinstall your newly customized shaft into your headlight switch assembly.



**American  
Autowire**

www.americanautowire.com 856-933-0801

PART #

**510321**

DESCRIPTION:

Headlight Switch  
1966 - 77 Ford Bronco  
Classic Update Series

92970084 instruction sheet rev 0.0 5/15/2012

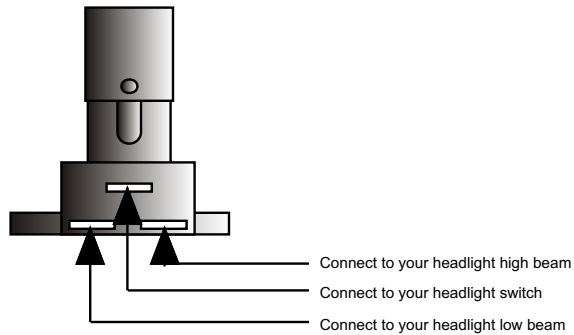

Connect the Dimmer Switch wires as shown above.

1. The top center terminal of the Dimmer Switch is connected to the Headlight switch.
2. The terminal on the right side is connected to your headlight high beam terminal.
3. The terminal on the left side is connected to your headlight low beam terminal.

another wiring product by...



150 Heller Pl #17 W Bellmawr, NJ 08031 856-933-0801

PART #

**500042**

DESCRIPTION:

**DIMMER SWITCH**

92964573 instruction sheet Rev 3.0 6/29/99

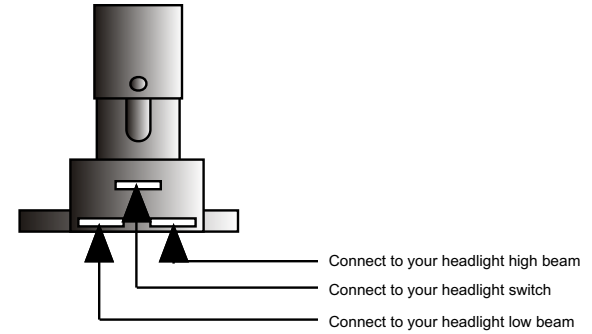

Connect the Dimmer Switch wires as shown above.

1. The top center terminal of the Dimmer Switch is connected to the Headlight switch.
2. The terminal on the right side is connected to your headlight high beam terminal.
3. The terminal on the left side is connected to your headlight low beam terminal.

another wiring product by...



150 Heller Pl #17 W Bellmawr, NJ 08031 856-933-0801

PART #

**500042**

DESCRIPTION:

**DIMMER SWITCH**

92964573 instruction sheet Rev 3.0 6/29/99

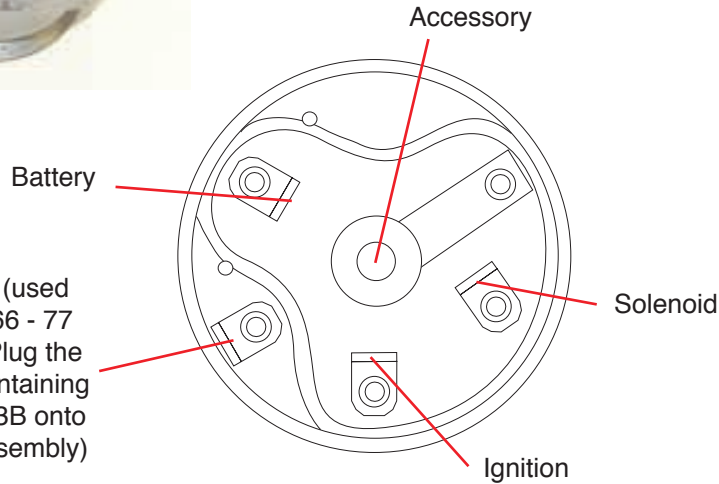

150 Heller Pl #17 W Bellmawr, NJ 08031 856-933-0801

PART #

**510128**

DESCRIPTION:

Ignition Switch  
Various Ford Applications  
Classic Update Series

92969235 instruction sheet rev 2.0 2/4/2014

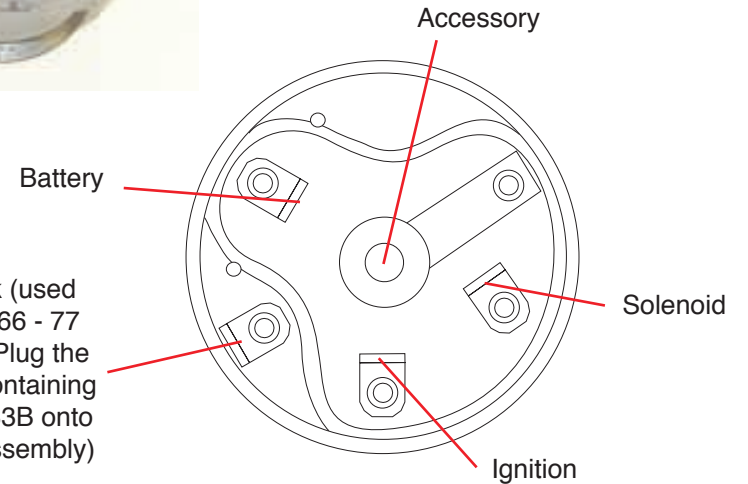

150 Heller Pl #17 W Bellmawr, NJ 08031 856-933-0801

PART #

**510128**

DESCRIPTION:

Ignition Switch  
Various Ford Applications  
Classic Update Series

92969235 instruction sheet rev 2.0 2/4/2014



1. Install the new switch into your dash using your original bezel and nut.
2. Attach the knob to the shaft and tighten the locking screw.
3. Plug the wiper connector from branch 3 of the 92970069 instruction set onto the wiper switch assembly now mounted in the dash to complete the switch installation.



www.americanautowire.com 856-933-0801

PART #

**510322**

DESCRIPTION:

Wiper Switch  
1966 - 77 Ford Bronco  
Classic Update Series

92970087 instruction sheet rev 0.0 5/15/2012



1. Install the new switch into your dash using your original bezel and nut.
2. Attach the knob to the shaft and tighten the locking screw.
3. Plug the wiper connector from branch 3 of the 92970069 instruction set onto the wiper switch assembly now mounted in the dash to complete the switch installation.



www.americanautowire.com 856-933-0801

**510322**

Wiper Switch  
1966 - 77 Ford Bronco  
Classic Update Series

92970087 instruction sheet rev 0.0 5/15/2012